

Please cite this paper as:

OECD (2012), "ICT Applications for the Smart Grid: Opportunities and Policy Implications", *OECD Digital Economy Papers*, No. 190, OECD Publishing.  
<http://dx.doi.org/10.1787/5k9h2q8v9bln-en>



OECD Digital Economy Papers  
No. 190

# ICT Applications for the Smart Grid

OPPORTUNITIES AND POLICY IMPLICATIONS

OECD

**Unclassified**

**DSTI/ICCP/IE(2011)2/FINAL**

Organisation de Coopération et de Développement Économiques  
Organisation for Economic Co-operation and Development

**10-Jan-2012**

**English - Or. English**

**DIRECTORATE FOR SCIENCE, TECHNOLOGY AND INDUSTRY  
COMMITTEE FOR INFORMATION, COMPUTER AND COMMUNICATIONS POLICY**

**Working Party on the Information Economy**

**ICT Applications for the Smart Grid**

**Opportunities and Policy Implications**

Taylor Reynolds; [taylor.reynolds@oecd.org](mailto:taylor.reynolds@oecd.org); +33 1 45 24 93 84 Arthur Mickoleit;  
[arthur.mickoleit@oecd.org](mailto:arthur.mickoleit@oecd.org); +33 1 45 24 91 32

**JT03314117**

Document complet disponible sur OLIS dans son format d'origine  
Complete document available on OLIS in its original format

**DSTI/ICCP/IE(2011)2/FINAL  
Unclassified**

**English - Or. English**

## FOREWORD

This report was presented to the Working Party on the Information Economy (WPIE) in June 2011. It was recommended to be made public by the Committee for Information, Computer and Communications Policy (ICCP) in October 2011. The report was prepared by Mr. Arthur Mickoleit. It is published on the responsibility of the Secretary-General of the OECD.

This document and any map included herein are without prejudice to the status of or sovereignty over any territory, to the delimitation of international frontiers and boundaries and to the name of any territory, city or area.

## TABLE OF CONTENTS

FOREWORD .....	2
MAIN POINTS .....	4
INTRODUCTION .....	5
CURRENT AND FUTURE STAKES .....	6
The link between energy and electricity .....	6
A list of key electricity sector challenges .....	7
ROLE OF THE “SMART GRID” .....	10
Definition .....	10
Potential .....	11
Mapping ICT applications to electricity sector challenges .....	12
Increase the share of renewable energy in the electricity mix .....	13
Integrate distributed, small-scale electricity generation .....	16
Transmission and distribution grid management .....	18
Increase electricity storage capacities .....	21
Dynamic and real-time pricing for electricity consumption and distributed generation .....	22
Electricity conservation and energy-efficiency .....	22
Demand management .....	26
Integration of electric vehicles (and renewable energy sources) .....	28
POLICY IMPLICATIONS .....	32
Overarching challenges for policy makers .....	32
ICT-specific policy implications .....	34
Regulatory and networks issues .....	34
IT and IT sector issues .....	35
Security, resilience, privacy and exploitation of personal data .....	36
NOTES .....	38
REFERENCES .....	39

### Boxes

Box 1. The environmental impact of peak load .....	16
Box 2. Cloud computing potential for peak demand management .....	28

## MAIN POINTS

- The electricity sector is inextricably linked with global energy challenges and climate change since over two-thirds of global electricity is generated from the combustion of fossil fuels.
- The smart grid has great potential for driving innovation in the ways electricity is produced, managed and consumed. Applications of information and communication technologies (ICTs) and especially the opportunities provided by the Internet can help sustain electricity supply while limiting environmental impacts. ICTs are seen as promoting a wider integration of renewable energy sources, promoting low-carbon transport options including electric vehicles and inducing structural shifts in electricity consumption.
- Innovative applications for final consumers clearly revolve around the smart meter. More than a hardware device, it has the potential to balance traditional information asymmetries between electricity producers and consumers and to stimulate informed energy conservation choices; over 10% of an individual household's electricity consumption can be cut by simply providing better information (or providing information *in better ways*). Reductions in "peak demand" can directly contribute to lowering greenhouse gas emissions.
- There is also significant innovation in the "back-end" of electricity sector operations. Improved monitoring and networked IT systems can help limit losses of electricity along the way and thereby improve capacity utilisation and avoid pollution; such losses represent on average 8% of production worldwide but over 15% in individual countries.
- Integrated information and communication systems spur the emergence of new value chain entrants and business models. A prominent example are electricity supply aggregators operating "virtual power plants". Specialised IT services and infrastructure providers develop targeted solutions for the electricity sector. Moreover, "smart" operations in the ICT sector itself can contribute to limiting environmental impacts with cloud computing holding potential for effectively tackling peak electricity demand.
- However, overarching policy issues need to be addressed to improve co-ordination and flows of information between smart grid stakeholders, to explore sustainable financing options for smart grids and to ensure acceptance by and engagement of consumers and society at large.
- ICT-specific policy implications involve converging energy and telecommunications services, changing connectivity requirements, evolving roles for ICT companies as electricity sector partners and the resulting skills needs for IT professionals. Policy makers can facilitate innovation and co-ordination across IT and energy sectors. But they also have an important role to play in ensuring interoperability and openness of smart grids while at the same time securing critical infrastructures, safeguarding individual privacy and developing sound principles for the commercial use of personal data.

## INTRODUCTION

This report discusses “smart” applications of information and communication technologies (ICTs) for more sustainable energy production, management and consumption. The “smart grid” is a particular application area expected to help tackle a number of structural challenges global energy supply and demand are facing. The challenges include:

- The direct impact of energy supply industries on climate change and other environmental impact categories.
- Explosion of energy demand worldwide over the past decades.
- Wider uptake of renewable energy sources in national “energy mixes”, which holds specific challenges.
- Accelerating diffusion of electric vehicles, which will impact volumes and patterns of electricity demand.
- Provision of reliable and secure national electricity infrastructures.
- Electricity provision to unserved parts of the population in developing countries.

This report discusses these challenges in greater detail and links them to innovative applications of ICTs. These linkages provide the basis for what is termed the “smart grid”, *i.e.* electricity networks with enhanced capacities for information and communication. In concluding, this report outlines policy implications for government ministries dealing with telecommunications regulation, ICT sector and innovation promotion, consumer and competition issues.

But policy implications can reach further than that and the European Commission’s recent Energy Strategy is just one example of how ICTs are expected to mitigate environmental challenges across the board. It points to the importance of ICTs *“in improving the efficiency of major emitting sectors. [They] offer potential for a structural shift to less resource-intensive products and services, for energy savings in buildings and electricity networks as well as for more efficient and less energy consuming intelligent transport systems”* (EC, 2010).

Similarly, OECD ministers see ICTs and the Internet as a key enabling technology for Green Growth, a fact that resounds in the Green Growth Strategy report presented in May 2011 (OECD, 2011a). However, the magnitude and persistence of energy and electricity challenges require joint agendas of ICT firms and utilities, ICT and energy policy makers, as well as bridging dispersed academic and civil society communities around the smart grid.<sup>1</sup> A major conclusion of this report is therefore that there is an urgent need for co-ordination between energy and ICT sectors, integrating also inputs from stakeholders in transportation, construction and related sectors.

This report deals with strategic issues in the electricity sector. However, it is clear that challenges in other utility business areas such as the provision of water, gas or heating bear some similarities. Challenges in these areas also require innovation in order to guarantee the reliable and sustainable provision of supplies. ICTs can be a major component there and some smart ICT applications outlined in this report might be used in those contexts too.<sup>2</sup>

## CURRENT AND FUTURE STAKES

Global energy challenges are immense. Over the past three decades, global energy production and consumption have accelerated to unprecedented degrees. Between 1973 and 2008 (35 years) total energy production has basically doubled (OECD calculations based on IEA *World Energy Statistics*). This is problematic because close to 70% of global energy demand is satisfied using energy generated from sources that emit relatively large amounts of greenhouse gases (carbon dioxide, CO<sub>2</sub>, is one of them). The energy supply sector, which is responsible for one quarter of global greenhouse gas (GHG) emissions, has therefore become a major target of climate change mitigation action (IPCC, 2007).

### The link between energy and electricity

Electricity is a pivotal element in understanding global energy challenges. Electricity by itself (its existence) or its consumption does not emit greenhouse gas emissions. It is an energy carrier, a sort of intermediary, between the supply of primary energy sources (*e.g.* coal) and the demand for energy-using services (*e.g.* transport, heating, lighting) (see Figure 1). It is, in fact, *the* main energy carrier used around the world for residential, commercial and industrial processes next to fuels and heat.

**Figure 1. Relationships between energy sources, carriers and demand**

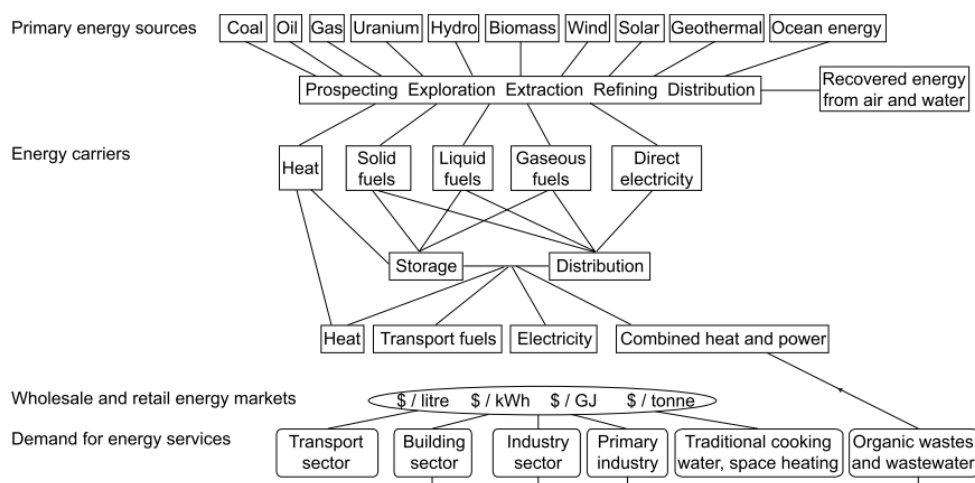

Source: IPCC, 2007 (Chapter 4, "Energy supply").

The climate challenge related to electricity stems from the fact that over two-thirds of global electricity production is generated from the combustion of fossil fuels (IEA, 2010a). The electricity producing sector is a major user of fossil fuels, responsible for one-third of global fossil fuel use (IEA, 2010b). As a result, electricity plants have outpaced other contributors in terms of greenhouse gas emissions (GHGs) since the 1970s, making mitigation action in the electricity sector a necessary condition for sustainable economic growth worldwide (see Figure 2).

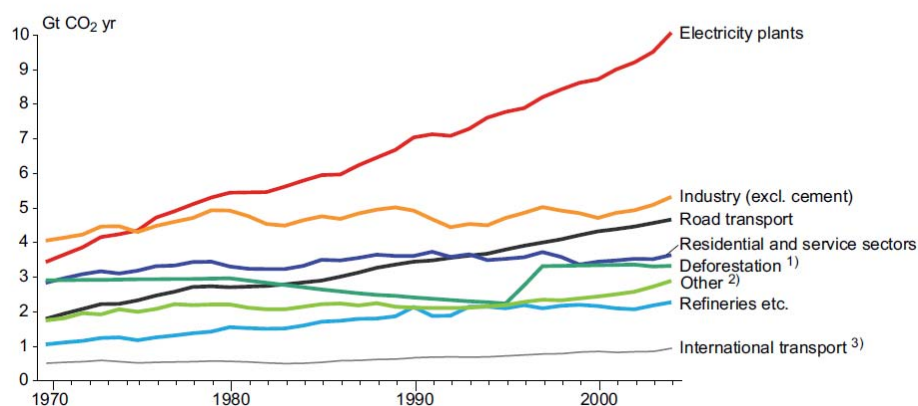
**Figure 2. Sources of global CO<sub>2</sub> emissions, 1970-2004**

See source for explanatory notes.

Source: IPCC, 2007 (Chapter 1, "Introduction").

Further to the past increases in contribution to climate change, the electricity sector globally is facing structural challenges that will amplify the detrimental effects of business-as-usual practices on the environment. The emerging shift from internal combustion engines to electricity-powered engines is only one of them. Further challenges involve the provision of electricity in developing countries, industrial demand for electricity as well as a reliable electricity supply. The latter factor expands the “smart grids” discussion beyond environmental considerations to include the economic development dimensions of electricity. Reliable electricity supplies are necessary to power manufacturing and services provision, to empower poor populations, etc. The required investments to satisfy energy demand will be large if no changes are made to the volumes of energy consumption and their patterns.

### A list of key electricity sector challenges

To understand the potential of ICT applications in the electricity sector, it is important to get a solid understanding of the key challenges in the sector. On a global scale, the main energy sector challenge is the dependence on fossil fuels such as oil, gas and coal. This dependence has environmental and economic implications. From an environmental perspective, it is evident today that the combustion of fossil fuels is a major contributor to anthropogenic causes of climate change. Moreover, the combustion of fossil fuels has other polluting characteristics, notably acidification of land and water resources through emissions of sulphur and nitrogen oxides (*e.g.* “acid rain”). From an economic standpoint, dependence on scarce resources that, in the case of most OECD countries, need to be imported creates vulnerabilities to changes in prices and availability. Political and social unrest in oil-exporting countries have contributed to price shocks in the 1970s and 1980s leading to “car-free” days in some countries. In 2008 and 2011, these issues have re-emerged with unrest in a number of major oil-exporting countries.

Growing levels of living standards and industrialisation in emerging economies expands the demand for energy originating in non-OECD countries. About half of global electricity production took place in the OECD area in 2008; this was down from over two-thirds in the 1970s (IEA, 2010*a*). Energy demand in the OECD is expected to remain flat over the next two decades while the global total is projected to more than double (increase by 151%), driven by growth in emerging economies (IEA, 2010*c*).

As a result, a growing number of countries compete for scarce energy resources. More and more energy-exporting economies will need to satisfy domestic energy demand as economic development



advances, creating further pressures on global availability of oil resources. New reserves for fossil fuels might be discovered and exploited, *e.g.* through deep water drilling, Arctic exploration, shale gas. However, many of these approaches bear considerable environmental risks and face strong opposition by public opinion in some OECD countries. The general trend in OECD governments is therefore to explore alternative ways of energy production and to promote energy conservation measures. The European Commission, for example, has repeatedly stressed the EU's vulnerability to price fluctuations for energy sources; taken together the bloc of countries is the world's biggest energy importer. The EU has therefore set itself the objective to increase the share of renewable energy generation to 20% by 2020 and to increase energy efficiency by 20% over the same period.

The use of ICTs in a smart electricity grid is not a panacea or a silver bullet to address all of these major challenges. But ICTs and the Internet will allow countries to manage growing amounts of electricity produced from renewable energies, new modes of transport and living as well as other structural shifts in electricity supply and demand. Technologies and the use of data enable improved and more accurate information about the availability, price and environmental impacts of energy, thereby empowering producers and consumers to make more informed energy conservation choices. The Internet especially gives rise to a new generation of businesses providing services around electricity, adding further value and innovation to the energy sector value chain.

A look at the traditional energy sector value chain translates global energy sector challenges to tangible areas for action where ICT technologies already provide solutions or might be able to do so in the future. Figure 2 shows a simplified view of the energy sector value chain.

**Figure 3. Stylised electricity sector value chain**

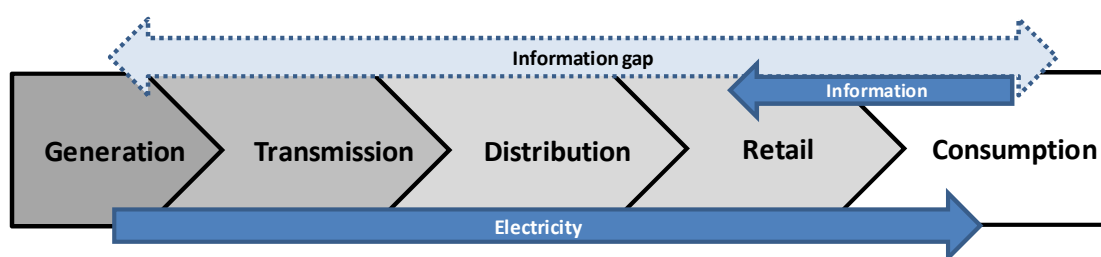

- **Electricity generation** is the process of converting primary energy sources to electricity as the energy carrier. This includes conventional power plants (nuclear, oil, gas), incinerators (waste to electricity), on-site generators, etc. but also wind turbine parks, solar panel installations, etc.
- **Electricity transmission** is the first step in the transportation of energy, encompassing high voltage transmission lines (overhead, underground, seabed) that typically use alternating current (AC). Transmission systems under high voltage and using direct current (HVDC) are an important element in energy systems where generation is far from the sites of consumption (*e.g.* off-shore wind parks or hydro power). The largest transmission line today covers a distance of 2 000 km between a large hydropower plant under development in the Chinese provinces of Sichuan and Yunnan and the city of Shanghai. Use of direct current is typically associated with lower physical losses of electricity than alternating current, but requires additional equipment investments when compared with AC.
- **Electricity distribution** refers to power delivery to the point of consumption, *i.e.* medium and low voltage power lines that use almost exclusively alternating current (AC). These distribution lines can span several kilometres starting at substations that transform high voltage electricity to medium and low voltage electricity, ending at electricity meters at the customer site.

- **Electricity retail and value-added services** refer to the commercialisation of electricity to final customers – residential and commercial. Retailing traditionally includes the metered provision of electricity against the payment of fixed fees (*e.g.* monthly subscription) and per-use fees. Opening up of electricity markets in many OECD economies led to increased competition in electricity retail, *e.g.* from virtual electricity retailers with no direct access to installed generation capacity (as well as competition in other parts of the value chain, see below). It also enabled the provision of value-added services by companies other than those involved in earlier steps of the electricity value chain, *e.g.* service providers offering electricity consumption analysis and optimisation advice.
- Finally, **electricity consumption** covers all electricity-using activities that take place on the customer’s account or premises. The boundary is drawn at the electricity meter where utility discretion typically ends and only the customer is authorised to turn on or off electricity-using devices.

Table 1 provides an overview of areas where electricity sector challenges relate to tackling climate change. It uses the value chain steps highlighted above complemented by energy storage, which is becoming an important issue for co-ordination between stakeholders, as shown in the next section. The list is not exhaustive, but points to the major global electricity sector challenges. Challenges related to security and privacy in this context will be discussed in the next section and will come back in the final section on policy challenges. Issues such as expansion of networks and fostering of competition are important, but are not discussed here in order to keep the focus on ICTs for the mitigation of environmental challenges in the electricity sector.

**Table 1. Major electricity sector challenges along the value chain**

<b>Generation</b>
Renewable energy generation
Distributed, small-scale electricity generation
<b>Transport (Transmission &amp; Distribution)</b>
Transmission and distribution grid management
<b>Storage</b>
Storage capacities (physical and logical)
<b>Retail</b>
Dynamic and real-time pricing for electricity consumption and distributed generation
<b>Consumption</b>
Electricity conservation and energy-efficiency (Automated) demand management
Integration of electric vehicles (and renewable energy sources)
Facilitate access to electricity in developing countries (Electrification)

In the context of competition it is important to highlight that functional separation in the electricity sector has occurred in most OECD countries. Formerly state-owned and vertically integrated, utilities in OECD countries went through significant waves of privatisation in transmission and distribution beginning in the 1970s. Monopolies in generation, transmission and distribution were split up in order to enable competition in the areas of transmission system operators (TSOs) and distribution system operators

(DSOs). Further steps towards enabling greater competition in the energy sector followed in the 1990s when retail electricity markets were liberalised in many countries.

Consumers in most OECD countries today have a choice between electricity suppliers that differentiate their offers based on prices, but also other criteria, *e.g.* share of renewable energy sources in electricity supplied. However, national differences across the OECD remain wide in terms of numbers and market shares of competitors to the incumbent. Competition issues in the areas of generation, transmission and distribution also remain on the agenda of policy makers and regulators.<sup>3</sup>

## ROLE OF THE “SMART GRID”

### Definition

Various definitions of the smart grid exist. Before proceeding towards a working definition for the purpose of this report, it is important to highlight that the smart grid is not a product. It must be seen as a continuous process of modernising existing electricity grids and of designing future grids. The smart grid is meant to address a number of key challenges – environmental and economic – that the electricity sector is facing. The use of ICTs and Internet applications are at the centre of this modernisation.

Smart grids can essentially be defined by their **functions** and their **components**. Environmental and economic challenges in the electricity sector transcend individual steps in the value chain. The smart grid is therefore expected to address the key challenges stakeholders in the sector are facing: mitigation of climate change, disruptions in supply of conventional energy sources, exploding global demand for electricity, wider diffusion of renewable energy sources, accelerating use of electric vehicles and louder consumer demands for greater transparency.

Turning to the components, smart grids are typically described as electricity systems complemented by communications networks, monitoring and control systems, “smart” devices and end-user interfaces (*c.f.* OECD, 2010a, 2009a). A definition that blends both functions and components is proposed by the IEA and is helpful in guiding the analysis of ICT applications in this report:

"A smart grid is an electricity network that uses digital and other advanced technologies to monitor and manage the transport of electricity from all generation sources to meet the varying electricity demands of end-users. Smart grids co-ordinate the needs and capabilities of all generators, grid operators, end-users and electricity market stakeholders to operate all parts of the system as efficiently as possible, minimising costs and environmental impacts while maximising system reliability, resilience and stability." (IEA, 2011)

Figure 4. ICT application domains in the smart grid

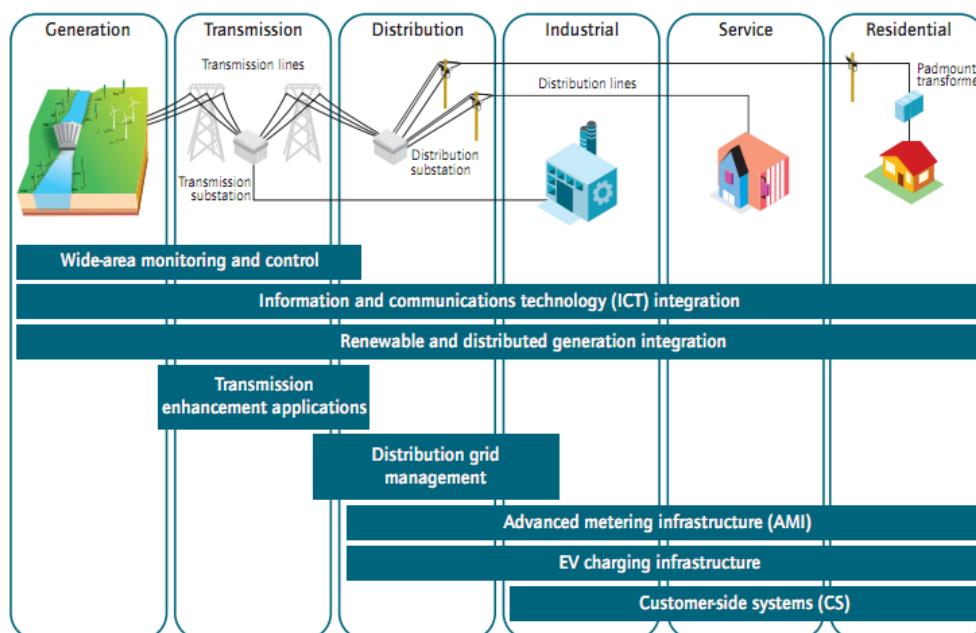

Source: IEA, 2011.

## Potential

The smart grid is expected to significantly lower electricity-related greenhouse gas emissions in the future. Direct reductions are typically attributed to more efficient processes in electricity generation, transmission and distribution as well as to energy conservation at customer sites. Indirect reductions are expected in the sense that the smart grid will facilitate wider diffusion of renewable energy sources as well as their integration with wider uptake of electric vehicles.

It is difficult to quantify the actual environmental benefits of the smart grid. Measurements must take into account a wide range of enabling opportunities, but also direct and systemic impacts related to increased use of ICTs in the domain of electricity (*c.f.* OECD, 2010a). Most studies highlight the expected positive impacts of smart grids. Under the IEA Blue MAP Scenario, which is based on a methodology developed by the US Electric Power Research Institute (EPRI), smart grids could help cut global CO<sub>2</sub> emissions from electricity generation in the year 2050 by half (*i.e.* compared to the baseline scenario for that year; IEA, 2010b).

The main levers are greater integration of renewable energy sources and electric vehicles (Figure 5).<sup>4</sup> Unfortunately, only a few studies seem to include direct energy use of ICTs and potential rebound effects from wider diffusion in their scenarios. A 2004 study by the IPTS confirms the expected positive net effect ICTs will have on GHG emissions in the electricity sector. It does not, however, provide details on how much of the efficiency gains are “eaten up” through other factors of increased electricity consumption. The European SEESGEN-ICT project on ICTs in the smart grid includes the angle of minimising environmental impacts of the ICT applications themselves.<sup>5</sup>

**Figure 5. Smart Grid CO<sub>2</sub> reductions in 2050, compared to Baseline scenario**

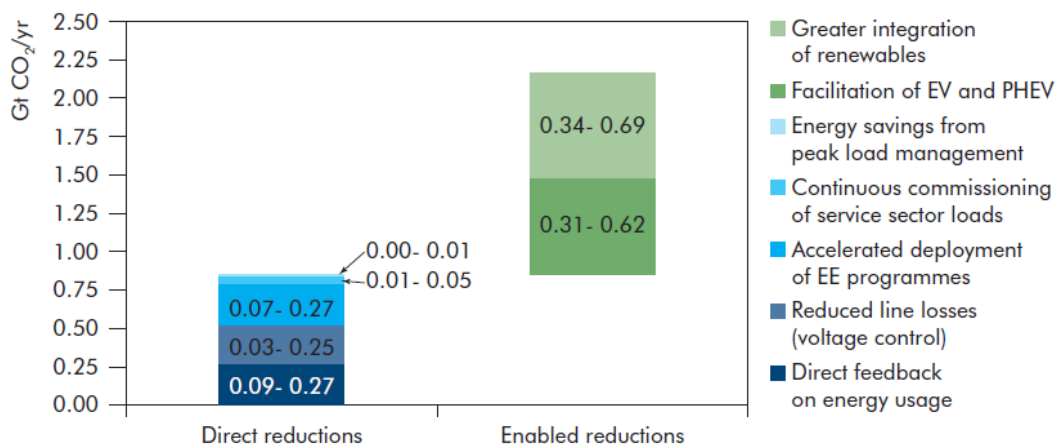

Source: IEA (2010b).

### Mapping ICT applications to electricity sector challenges

Table 1 provides an overview of the electricity challenges outlined in this report and ICT applications addressing these challenges. It expands on the general notions of ICTs presented in Figure 4, by detailing the prevalent ICT applications per electricity sector domain. The remainder of this section provides analysis of the role of ICT applications in tackling each of the challenges. It also highlights how ICTs are supporting new business models and changes in the value chain of the energy sector at large.

**Table 2. Mapping “smart” to “grid”**

Electricity sector challenges and potential ICT applications

Electricity sector challenges	ICT applications
<b>Generation</b>	
Renewable energy generation	<ul style="list-style-type: none"> <li>• Smart meters</li> <li>• Vehicle-to-grid (V2G) and grid-to-vehicle (G2V)</li> </ul>
Distributed, small-scale electricity generation	<ul style="list-style-type: none"> <li>• Virtual power plants</li> <li>• Vehicle-to-grid (V2G) and grid-to-vehicle (G2V)</li> <li>• Smart meters</li> </ul>
<b>Transport (Transmission &amp; Distribution)</b>	
Transmission and distribution grid management	<ul style="list-style-type: none"> <li>• Sensor-based networks</li> <li>• Embedded systems and software</li> <li>• Integrated software systems and application programming interfaces (APIs)</li> <li>• Smart meters</li> <li>• Communications protocols, including machine-to-machine communications (M2M)</li> </ul>
<b>Storage</b>	
Storage capacities (physical and logical)	<ul style="list-style-type: none"> <li>• V2G, G2V and vehicle-to-home (V2H)</li> <li>• Smart meters</li> <li>• End-user interfaces</li> </ul>
<b>Retail</b>	
Dynamic and real-time pricing for electricity consumption and distributed generation	<ul style="list-style-type: none"> <li>• Smart meters</li> <li>• End-user interfaces</li> </ul>
<b>Consumption</b>	
Electricity conservation and energy-efficiency	<ul style="list-style-type: none"> <li>• End-user interfaces</li> <li>• Smart meters</li> <li>• Electricity data intelligence</li> </ul>
(Automated) demand management	<ul style="list-style-type: none"> <li>• End-user interfaces</li> <li>• Smart meters</li> <li>• Communications protocols, including M2M</li> <li>• Smart building technologies</li> <li>• Smart electronic devices</li> <li>• Data centres and cloud computing</li> </ul>
Integration of electric vehicles (and renewable energy sources)	<ul style="list-style-type: none"> <li>• End-user interfaces</li> <li>• Smart meters</li> <li>• V2G, G2V</li> <li>• Communications protocols, including M2M</li> <li>• Integrated software systems and APIs</li> </ul>
Facilitate access to electricity in developing countries (Electrification)	

***Increase the share of renewable energy in the electricity mix***

Electricity generation from renewable energy sources such as wind, sun or water constitute a major avenue for mitigation of climate change. It is also important for strategies to limit other factors of pollution stemming from fossil fuel combustion, *e.g.* “acid rain”. However, in 2007 a full 70% of global electricity was still generated through the combustion of fossil fuels and only 18% was generated using renewable energy sources. Under baseline scenarios this share will not change by 2050, as opposed to the CO<sub>2</sub>

emissions from electricity generation, which would double over the same period (IEA, 2010a). This divergence will result from absolute increases in electricity demand around the world.

Wide-scale integration of renewable energy sources for electricity generation steps up the need for flexible management of electricity generation, transport and storage. While renewable energy sources differ significantly in their characteristics, the timing of supply and demand is one of the major challenges commonly referred to as a barrier to higher uptake. Indeed, from a local perspective, wind and sun are intermittent power sources, *i.e.* do not necessarily supply sufficient power at times when demand is high. A study of wind power outputs in the United Kingdom, for example, shows that wind turbines worked at less than 6% of their capacity during four peak demand events in 2010 (Stuart Young, 2011) (see Box 1 for an explanation of peak demand and its impacts). This can pose a dual set of challenges: meeting demand when it is highest, *e.g.* people returning home in the evening, and providing what is termed “baseload” to the grid, *i.e.* satisfying the typical load on an operator’s electricity grid.

The smart grid provides opportunities to remedy local imbalances between demand for electricity and the supply of renewable energy. A study for the US state of North Carolina (over 9 million inhabitants) suggests that a considerable amount of load – over 70%, including baseload and peak load – can be provided from renewable energies, provided that ICTs are used to enable electricity storage, wider geographic scopes of the grid, effective demand management and dynamic pricing (Blackburn, 2010). These four approaches are discussed in more detail across this section, but an immediate focus is set here on how ICTs can help increase the share of renewable energy sources in the national “electricity mix”:

- **Batteries** can be used to store electricity at times when supply outweighs demand and to supply electricity back to the grid when demand increases. Capacities of single batteries are improving and so is the cost-efficiency of battery technologies (see Inage, 2009). But “smart” solutions of storing electricity can complement single-purpose batteries connected to the electricity grid. Using electric cars for storage and off-grid supply of electricity is commonly discussed in this area and requires sophisticated management systems and useable human interfaces to be effective. Potential risks might occur from global shortages of the raw materials used in batteries production due to limited supplies and increasing demand (OECD, 2011b). Disposal and recycling issues related to batteries also need addressing.
- **Improved interconnections** between regional and national grids of different operators can expand the geographical scope for use of electricity generated from renewable energy sources. Electricity grids of TSOs and DSOs tap into a limited number of electricity generators, namely the ones connected to “their” grid. Some electricity trade takes place via dedicated interconnections between regional or national grids. OECD countries interchange on average 4% of electricity consumed, although with large variations across countries (*e.g.* over 20% in Portugal or the Netherlands, but only 2% in France or Spain; from OECD calculations based on *IEA World Energy Statistics*). But improvements to these connections remain high on the agenda of energy policy makers as peak electricity demands across countries are increasing. Interconnections also facilitate the integration of renewable energy sources for electricity generation. Improved cross-border exchanges allow utilities with excess capacity to export electricity to places where demand is high. Researchers have developed scenarios whereby optimal interconnections between European and Northern African countries could allow renewable energy sources to become the predominant source of electricity in the countries affected.<sup>6</sup>
- **Demand management** can help grid operators keep the required balance between electricity supply and demand. Price incentives and better information can guide commercial and residential customers in their electricity use patterns. Grid operators in most countries provide incentives to

industrial customers to lower their load on the electricity grid at peak times (see *Automated Demand Management* below). Comparable mechanisms in the residential sector remain largely under-exploited because of the lack of easily accessible information for consumers about the environmental impacts of their electricity use. Lack of effective communications channels between electricity suppliers and consumers touches virtually all countries. A press release by French utility EDF anticipating a surge in electricity demand on an extremely cold winter day in 2010 is just one example of the great potential for improving direct information exchange between utilities and their customers through the use of ICTs.<sup>7</sup> It is evident that the use of ICT solutions such as smart meters, or even simpler communications channels such as text messaging, would greatly increase the range of recipients of such warnings.

- **Dynamic pricing** can alleviate some of the adverse effects of retail electricity prices that remain largely disconnected from the supply of (renewable) electricity at any given time. The Internet provides ample opportunities to make demand management more effective through smart meters, dynamic pricing and improved exchange of information across the electricity sector value chain.



### Box 1. The environmental impact of peak load

Electricity demand (*i.e.* the grid's "load") fluctuates significantly over the course of a year and also during the course of a day. Peak demand typically correlates with extreme weather conditions (heat or cold waves), structural peak times (workday evenings) and major global events (finals of major sporting events, Olympic opening and closing ceremonies, royal weddings). Figure 6 shows the number of hours that an average load occurred during 2008. In France and Germany, grid load in a year can be as low as 40 GW, but can double to 80GW at times of peak demand. Utilities combine this knowledge with historical load statistics to estimate the volume of peak load up to several days ahead.

Part of the problem is that peak loads across the OECD are on the increase – both in terms of volume and their duration. Managing these increases requires disposing of generation reserves that can be turned on relatively quickly. This trend has direct environmental implications given that peak demand is typically satisfied by reverting to back-up power plants that generate electricity from fossil fuel combustion. During a cold winter day in 2010 in France, for example, utility EDF mobilised over 6 GW of combustion-based power plants to be able to meet peak demand. It is worrying that the need for peak demand capacity continues to grow. In the United States, peak load is estimated to grow at an annual rate of 1.7% until 2019. The resulting absolute increase of US peak demand by 140 GW would require the equivalent of 600 additional coal-fired power plants (alternatively: 1700 gas-fired power plants). This has obvious implications for national greenhouse gas emissions; and it poses challenges regarding infrastructure investments and grid stability.

Figure 6. Load duration curves for selected countries, 2008

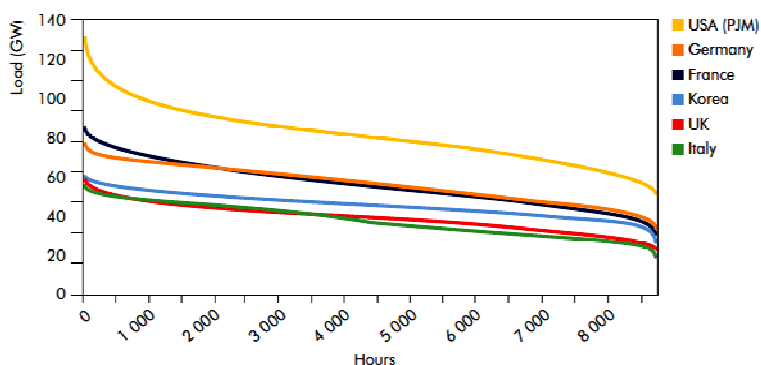

1. PJM is a Regional Transmission Organisation which is part of the Eastern Interconnection Grid in the United States.

Source: IEA, 2010b.

Sources: US FERC, 2009; IEA, 2010; OECD calculations based on US EIA, 2011 ("Existing Capacity by Energy Source"); EDF, 2010.

### *Integrate distributed, small-scale electricity generation*

The structure of electricity generation is undergoing dramatic changes worldwide. Coming from an era of "bulk generation", national "electricity mixes" are rapidly diversifying meaning that power plants become increasingly dispersed and diverse in their size. Combined heat and power plants (CHP) are, for example, closer to urban areas where heat and power use is high; so-called micro generation of electricity has seen great increases in some OECD countries, mostly in the form of roof-top photovoltaic installations. Most small-scale installations include an option to sell generated electricity back to grid system operators (as opposed to "off-grid" systems, which are not discussed here).

The trends of decentralised production, close to or at customer premises, and re-feeding to the grid are expected to continue (IEA, 2010b). The main advantages of this small-scale generation are wider diffusion

of renewable energy generation, competition in energy supply and the potential of fostering entrepreneurship and new business models. Notably, *aggregators* are entering the electricity sector value chain, intermediating between distributed electricity generators on the one hand and the market, TSOs and DSOs, on the other (*c.f.* FENIX, 2008).<sup>8</sup> In a way, the concept of aggregators in the electricity sector is similar to co-operatives in the agricultural sector in that they leverage the commercial potential of individual, small-scale production entities.

However, distributed, small-scale electricity generation has not been well integrated into national grid infrastructures. Sector experts point to a “fit and forget” approach whereby micro generators have been connected to the grid, but not well integrated in technical and commercial terms (FENIX, 2009a). Research projects in countries with high uptake (*e.g.* Germany, Spain and Denmark) have pointed to the consequent emergence of adverse effects, notably slowing deployment rates, increasing costs of operation and investment, threats to integrity and security of the electricity grid (FENIX, 2009a).

ICTs are the cornerstone in developments for **virtual power plants** (VPPs). VPPs facilitate the expansion of installed capacity from micro generation while addressing some of the challenges mentioned. The main feature of a VPP is the aggregation of several hundreds or even thousands of electricity-generating units into a single commercial and/or technical unit. The aggregating entity controlling the VPP has real-time communications downwards links with each generating unit. But it appears as a single actor on the electricity wholesale market or as a single supplier to the TSO or DSO (Figure 7). A distinct advantage of this system is that any types of generation and storage sources (*e.g.* wind, solar, hydro, electric vehicles) can be bundled to form a VPP. Fluctuations of individual components can be balanced out at a system level, thereby providing greater predictability of overall power supply from the VPP. Finally, the VPP also greatly increases the quality of electricity supply; grid operators favour power currents that arrive with stable voltages. This is made possible at the VPP level by controlling the power supply of individual units to the grid in real time.

**Figure 7. Schematic view of a virtual power plant**



The main ICT components of a VPP are interconnected control and management devices as well as an integrated software management system. In an EC-funded pilot project, a VPP was developed around the city of Alava, Spain, by Iberdrola and the Spanish grid operator *Red Eléctrica de España* (FENIX, 2009b). Although the combined generating capacity of 100MW is high enough to test local peak demand management schemes, the pilot project could not realistically assess the impact of VPP on managing a larger-scale grid, *e.g.* at the national level. Nevertheless, the main components used in the system provide a snapshot of what is necessary for any future VPP implementation:

- A **connected hardware device** installed at the generator’s premise enabling real-time communication between the electricity producer and the aggregator/VPP operator. While the FENIX project developed a dedicated “Fenix Box” for the purpose, **smart meters** are technically capable of delivering the functionality of billing consumption and generation of electricity. And they can technically be designed to send control signals to connected devices (see also *Automated demand management* below). But it depends on the actual implementation – so “future-proofing” of smart meters is important in this area. Using smart meters as a basis for virtual power plants

can also create financial incentives for wider adoption of smart meters and financing parts of it by final customers and/or aggregators.

- An integrated **software management system** that is able to aggregate and disaggregate individual electricity-generating units. The software management system is at the heart of the VPP as it allows the aggregator to observe, manage and control power flows between distributed electricity-generating units and the distribution or transmission grid. Necessary functionalities include user interfaces for visualisation of the system status and sending of control messages, as well as algorithms to support decision-making or even automated decision-making, taking into account system-inherent information as well as external factors, such as weather forecasts.
- A **communications network and protocol** that allow exchange of relatively small amounts of data (*e.g.* control signals, status information) between the electricity-generating unit and the VPP/aggregator. The VPP operator has to be able to send control signals to individual units in order to respond to sudden fluctuations in demand at the level of the distribution or transmission grid. Responses are expected in the order of minutes. In the FENIX project, the mobile data service GPRS and the IEC-104 protocol were used, but other types are possible too (*c.f.* OECD, forthcoming). Interoperability of communications protocols is necessary to uphold competition between various VPPs/aggregators and to avoid “lock-in” of customers. Communications protocols need to match the design requirements of the hardware device/smart meter that interfaces between the aggregator and the household.

### ***Transmission and distribution grid management***

Transmission lines transport electricity at high voltages from power plants to substations where electricity feeds into more local distribution systems. Balancing load and voltage across a transmission grid requires the ability to react to sudden changes, *e.g.* drops in output or peaks in demand. Effective management therefore requires close to real-time information about the electricity input to the grid (*i.e.* generation) and load on the grid (*i.e.* electricity demand at substations). But improved information is also necessary in order to increase overall transmission capacities over existing lines. There is strong resistance to further expansion of transmission grid infrastructures over land, so operators are facing the dilemma of necessary capacity expansion vs. public opinion and environmental impacts.

At the distribution level, operators are looking for ways to automate processes that link the substations (interfaces between transmission and distribution grids) with individual customer sites and individual electricity generators. Conventional control systems monitor current voltage, frequency and overall security and reliability of the network. In a move towards greater automation, grid operators can make use of enhanced sensors and IP-based communications systems to detect faults at the distribution system level. Interconnecting substations and customer meters can exchange control signals that determine which substation feeds electricity to/from which individual customer site and in the case of a fault have this changed automatically.<sup>9</sup>

Improved information about the status of the grid also helps prevent electricity losses. Transmission and distribution (T&D) losses occur as a natural phenomenon, but are typically higher in distribution grids where electricity is transported at low voltages. But losses can also be due to technical issues such as leaks, and non-technical issues such as theft. Around of 8% of electricity generated worldwide in 2008 was lost before it reached the consumer (Figure 8). It is estimated that these losses account for over 600 million tonnes of CO<sub>2</sub> emissions across major economies (MEF, 2009). In comparison, shares are higher in non-OECD countries and countries such as India, Malaysia or Venezuela lose around one quarter of produced electricity. Losses are also high in some OECD countries, *e.g.* Mexico, Turkey and Estonia. Given that

“energy mixes” in these countries are largely based on combustible fossil fuels, substantial amounts of pollution are emitted in order to make up for electricity losses.

**Figure 8. Electricity lost during transmission and distribution**

Share of gross domestic electricity production, OECD and selected non-members, 2008

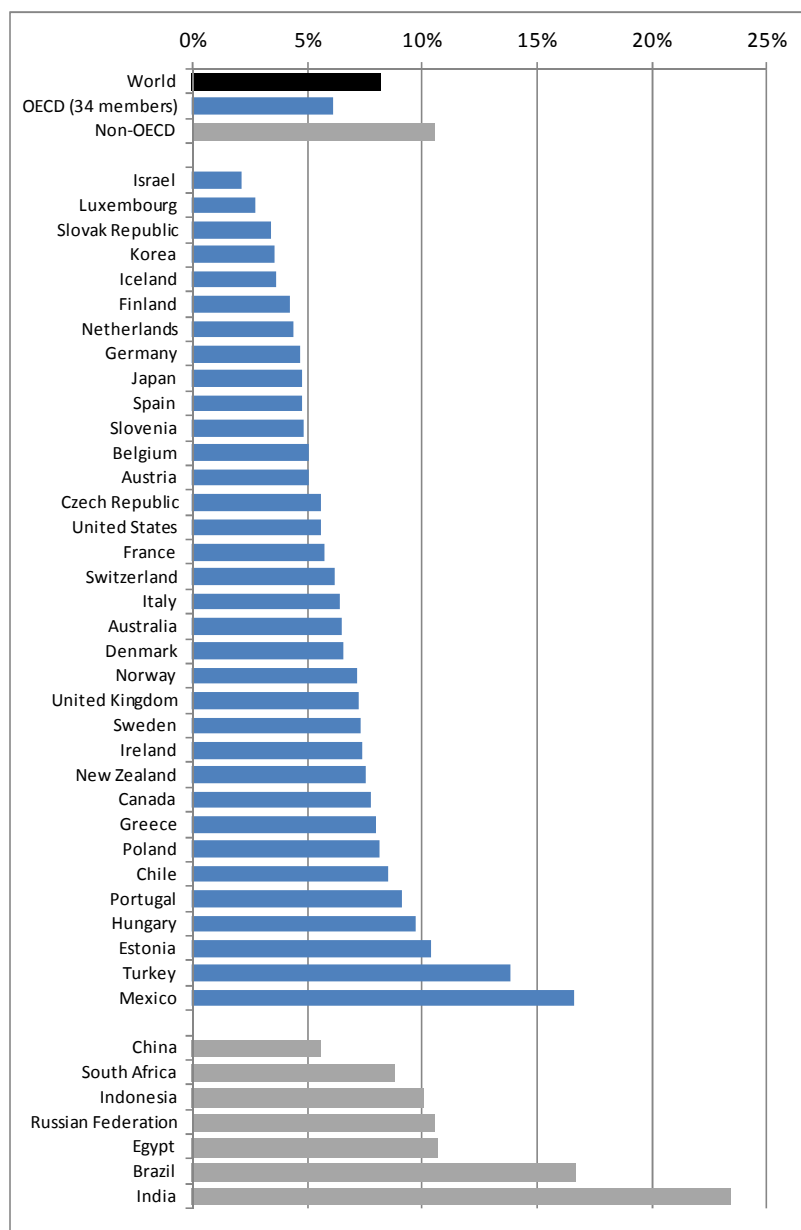

Source: OECD calculations, based on data in IEA, 2010a.

ICT-based applications are already in use at grid operators to monitor the status of national grid infrastructures. Applications include Intelligent Electronic Devices (IEDs), Phasor Measurement units (PMUs) and Supervisory Control and Data Acquisition (SCADA) systems.<sup>10</sup> However, requirements for communications and data handling are expanding rapidly: the increase in market actors due to liberalisation amplifies the need for fast and interoperable access to electricity data.

At the same time, renewable energies and dispersed energy production raise the complexity of national grids and make better and faster information provision a necessity. Finally, maintenance costs can be limited through targeted interventions in response to monitored events as opposed to interval-based inspection of assets. Information on the status of the grid needs to be accessible in ways that allow data exchange with utilities' proprietary systems as well as with potential non-utility users, *e.g.* regulators, policy makers and the general public.

The main components in modernising grid monitoring and control systems are:

- **Sensor-based networks.** Sensors across T&D lines can measure various characteristics such as voltage, temperature and tension (*c.f.* OECD, 2009a).
- **Embedded systems and software.** Depending on the system requirements, monitoring devices require more or less built-in intelligence. In a basic set-up, signals from the sensors must be converted into digital information and fed into a communications channel. But more sophisticated designs might be necessary to control thresholds or frequencies of sending data.
- **Integrated software systems, databases and APIs.** Information is fed into databases at utilities, grid operators or third party service providers. Software systems provide automated monitoring and control activities as well as interfaces for engineers. Through data standards and application programming interfaces, access to data about the grid status can be re-used by a large number of stakeholders, including aggregators, governments and individuals.
- **Smart meters and machine-to-machine communication.** Smart meters at customer premises can play two roles in terms of grid management. Coupled with machine-to-machine communication protocols they receive information and control signals destined for the customer and his/her appliances. Such signals can trigger the turning off or turning on of non-critical devices in the household. But smart meters also enable improved control over electricity consumption and billing. Detecting fraud, theft and tampering with devices is commonly cited as one of the reasons Italian utility Enel pioneered the roll-out of smart meters to over 30 million customers through 2006.<sup>11</sup>

Integrating these components is what makes the difference in a smart grid that combines business and technical intelligence. In recent years, ICT companies have been successful in exploring the large business opportunities of supplying advanced IT and communications services to utilities. Companies such as Current, Silver Spring Networks and Genscape have developed systems for the entire range of grid control needs. Genscape's technology provides a generalised overview of advanced grid monitoring in a smart grid (see Figure 9 below). The company developed a real-time information system reporting on voltage, temperature and other variables on transmission lines. The remote wireless devices collect information that is sent via various communications channels to the company's software systems and databases. Genscape then provides a web interface for direct access to the data as well as data access mechanisms for third-party applications (APIs). Functioning of this proprietary solution can be generalised to a large degree for grid monitoring applications.

**Figure 9. Components in a remote grid monitoring system**

(left: sender module; right: recipient module)

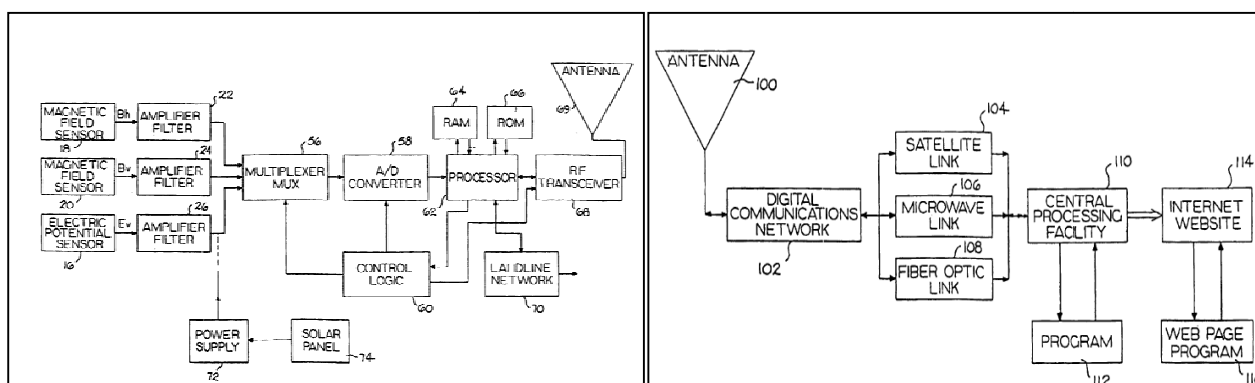

Source: Patent WO/2001/079872, "Apparatus and method for the measurement and monitoring of electrical power generation and transmission", published in 2001.

### *Increase electricity storage capacities*

Electricity storage is important for dealing with imbalances in supply and demand of electricity at a given time; it is also a means to ensure quality of electricity supply on the grid in terms of voltages. Storing electricity can be done using batteries or other physical solutions. Physical storage capacities of lithium or vanadium-based batteries are improving and so is their cost-efficiency (see Inage, 2009). But utilities and grid operators have been using electricity storage for a long time without recourse to actual battery devices. The most prominent example, pumped hydro storage, is based on a simple concept: excess electricity is used to pump water into dedicated reservoirs at higher altitude. This water is released into reservoirs at lower altitude when demand is high, thereby generating electricity. Over 200 such systems exist in the world with an overall capacity exceeding 100 GW (Inage, 2009).

Innovative conceptual approaches to electricity storage are necessary because single-purpose batteries will not suffice to satisfy storage requirements, at least not in the short term. Battery production and capacities are limited by prices, availability of finite raw materials as well as environmental and social sustainability issues (see OECD, 2010a). Research is being carried out to look at ways of using batteries in plug-in hybrid or full electric vehicles to store and request electricity on demand. The role of ICTs in this area is important in managing the flow of electricity between the grid and the electric car. **Grid-to-vehicle (G2V)**, **vehicle-to-grid (V2G)** and **vehicle-to-home (V2H)** schemes differ in their purposes, but all rely on IT and communications infrastructures to monitor and control the flow of electricity (see Tuttle & Baldick, 2010). Electricity flowing between the grid and the vehicle requires "aggregators" which are not dissimilar to the ones operating virtual power plants.

These aggregators manage the flow of information between grid operators and electric vehicles. Their main task is to send control signals to electric vehicles in cases of high availability of renewable energy (storing electricity in batteries) or high electricity demand (retrieving electricity from batteries). Depending on the agreement with the grid operators, necessary reaction time can vary between minutes and several hours (see Dennis & Thompson, 2009). Signals need to be sent via secured communications channels so that the origin of control signals and customer preferences can be authenticated and integrity of information guaranteed. Where sudden reactions are necessary, networks require low latency to efficiently control up to several thousand cars per aggregator.

An effective **end-user interface** is important so that customers can indicate preferences regarding vehicle charging and availability as well as for realising monetary incentives related to V2G and G2V schemes. Interfaces should allow for easy opt-in and opt-out possibilities regarding interactions with the grid. This gives customers the possibility to use batteries in the electric car as a source of electricity for the home, *e.g.* at times of peak demand with high electricity prices. Direct communications links sending information from the vehicle to grid operators or aggregators are possible using various wireless communications protocols. But in order to monitor, meter and account for the flow of electricity from/to individual customers, electricity meters with enhanced communications capabilities – *i.e.* **smart meters** – seem indispensable at home and at other locations where charging and discharging can occur. In schemes where the vehicle is expected to work off-grid, *i.e.* powering only the home or other premises, no communications with the wider electricity grid is required. In that case, the smart meter only acts as a communications link between the vehicle and appliances at the customer premise; to protect privacy it must be ensured that no information is shared with third parties.

### ***Dynamic and real-time pricing for electricity consumption and distributed generation***

Price signals can impact electricity consumption, provided they are communicated effectively. In the domain of wholesale electricity trading, large customers choose whether to engage in forward contracts or spot trading. Electricity prices for retail customers, however, are largely static and billing is based on estimates and periodic meter readings. Exceptions exist, *e.g.* on-peak/off-peak pricing, but most models remain static in that they do not reflect real-time price fluctuations in the market.

The smart grid is expected to expand existing real-time information systems to reach final customers. **Smart meters** as well as other **end-user interfaces** (*e.g.* web portals, mobile applications) can provide pricing information accurately and with little delay. Consumers can then make choices about conservation options (see below) or about feeding electricity back into the grid. Whether or not electricity consumption proves to be price elastic depends on a variety of variables. Large electricity customers are, in general, shown to benefit from dynamic pricing.<sup>12</sup> Individual customers, however, risk “losing track” of fluctuating prices that react to sudden changes in supply and demand. Electricity sector representatives note that the direct effects on overall electricity bills as a result of smart meters and dynamic pricing schemes are not clear either.<sup>13</sup> This means that long-term impacts depend not only on economic and technological criteria, but must take into account the design of smart meters and the way information is communicated to final users. The design of services offered by utilities and third parties in combination with dynamic pricing largely determines the degree to which individual customers and the entire system can reduce electricity consumption (see the following two sections).

### ***Electricity conservation and energy-efficiency***

Electricity conservation is a major avenue of limiting electricity-related greenhouse gas emissions. In OECD countries, electricity consumption continuously increased in recent decades, at an average annual rate of 2.6% since 1973, reaching 9 513 TWh in 2008 (IEA, 2010a). The residential, commercial and public sectors saw strongest increases; together with industrial customers they constitute the bulk of OECD electricity use (see Figure 10). Final energy consumers have therefore become a major target for energy conservation strategies. The IEA projects a scenario (“BLUE Map”) for 2050 whereby energy-efficiency measures for final consumers can help reduce global electricity demand by 13% compared to the baseline scenario (IEA, 2010b). This scenario notably accounts for growing demand from electric vehicles and other structural changes on the demand side.

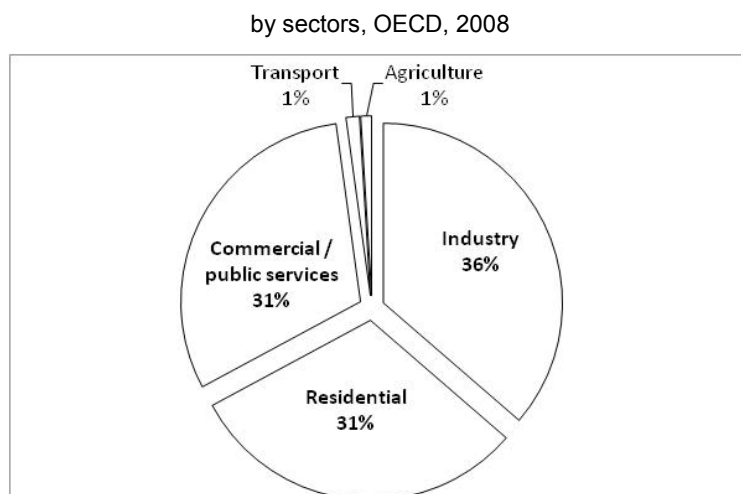
**Figure 10. Electricity consumption shares by sector**

Source: OECD calculations based on *IEA World Energy Statistics*.

Provision of information and communication services is essential in reducing final electricity use. The use of accessible interfaces between end users and electricity suppliers, coupled with advanced interpretation tools for energy data, can induce behavioural adaptation that also translates into systemic efficiencies. The **smart meter**, contrary to what its name implies, can be more versatile than simply metering electricity. In technical terms, advanced meter readings (AMR) refer to one-way communications, *i.e.* remote meter reading by the utility, whereas advanced metering infrastructure (AMI) refers to meters capable of sending and receiving data. AMI functions such as support for dynamic pricing and virtual power plants are outlined above. One of the main advantages, however, is that an AMI can be designed to increase transparency and information for electricity suppliers as well as users and potential third parties. Via the Internet, value chain participants can thus access and interpret data that so far was largely available to individual entities only. This has implications for the efficiency of power generation and provision and it notably allows residential, commercial and public customers to actively and accurately control electricity consumption. In summary, smart electricity meters are in general expected to provide the following functions:

- **Display of consumption-related information.** Smart meters provide digital information either directly on the devices or on connected devices in the household. The information includes real-time prices, accurate use numbers and implicit environmental costs. Information can take various forms, *e.g.* real-time or aggregated, and should provide a choice between display of electrical units (kW or kWh), monetary units or environmental units (GHG emissions).
- **Display and analysis of data on 3<sup>rd</sup> party devices and applications.** Application programming interfaces at the level of the smart meter or the utility IT system allow for the exchange of data with specialised devices or applications. A variety of 3<sup>rd</sup> party software and hardware is already available that use detailed electricity data to inform consumers. Google's PowerMeter, for example, can receive information from households equipped with smart meters of electricity suppliers Yello Strom (Germany), first:utility (United Kingdom) or SDG&E (United States).
- **Accurate metering and billing.** The majority of electricity customers in OECD countries pay their bills based on estimates by the utility, which are then adjusted after readings in regular, but larger intervals (sometimes as infrequently as once per year). Smart meters permit more frequent



billing periods, allowing customers to adapt quickly to unintended or undesired consumption patterns.

- **Dynamic pricing and billing.** As discussed earlier, dynamic pricing refers to both electricity consumption and provision by individual customers. The accurate metering function of smart meters coupled with two-way communications between electricity retailer and customer enable more dynamic pricing schemes than with traditional meters.
- **Remote information, metering and control.** Smart meters provide an interface for the management of individual sites of electricity consumption and generation (VPPs, V2G, G2V). They also allow the programming of automated responses to peaks in electricity demand across a grid. Responses can include control of individual electrical appliances and are part of the wider domain of home automation or “domotics” (see discussion below on *demand management*).

Smart meters have great potential for energy conservation, but **design choices** determine actual success rates. This covers user interfaces as well as internal workings, data and communications interfaces of smart metering devices. Regarding the design of end-user interfaces, it is largely accepted that households will “pick low-hanging fruit” in energy savings by simply providing better and more accessible information about their consumption; a survey of existing trials and roll-outs suggests that households save up to 12% of their usual electricity consumption. On a system-wide scale, these individual savings are estimated to be able to translate into a reduction of up to 6% of household electricity consumption in the United States (Ehrhardt-Martinez *et al.*, 2010). However, the interaction between technology and user is a key determinant of the direct impacts and larger outcomes. The form of feedback, its frequency and other characteristics, greatly impact on the reactions of diverse populations (categorised by gender, age and education) to more detailed electricity use information (*c.f.* OFGEM, 2010; Darby, 2009).

Field experiences testify to the importance of well-designed hardware, software and the services related to smart meters. In 2009, consumer complaints in the smart meter roll-out by PG&E across its operating area in California, United States, quickly turned public opinion against the technology. An independent report pinned higher bills down to a series of events, some of which were beyond the utility’s control, but the public relations damage was done.<sup>14</sup> In Germany and France, consumer organisations are pointing to a lack of transparency for and involvement of consumers, notably with regards to pricing and privacy.<sup>15</sup> In the Netherlands, a mandatory national roll-out was stopped by legislators due to unresolved privacy issues. These experiences underline that early involvement of consumers and addressing their concerns can help smooth the transition towards the smart grid.<sup>16</sup>

Design also matters for compatibility of smart meters with requirements of future applications and services. Electricity flowing to/from appliances and electric vehicles can be controlled using smart meters, but there is wide scope for further interactions with other devices. Data and communications interfaces need to be able to accommodate authorised access to data by consumers, utilities, aggregators and third parties such as mobile application developers. Protocols for data exchange need to balance criteria such as interoperability and efficiency; text-based data exchange formats such as XML are expected to provide distinct advantages given that they can be interpreted by many existing devices and generate relatively little traffic. Some of these interfaces will exchange information between machines only, *e.g.* for home automation, using a set of wired and wireless technologies available today (*c.f.* OECD, forthcoming). However, any analysis of requirements can only determine the most suitable existing technology today. Future-proofing of “smart” devices and applications for the electricity is particularly important given the long life-spans of assets (up to several decades). If regular replacement is not an option, standards for (remote) firmware updates and other upgrade options are necessary. This is one of the reasons the US National Institute of Standards and Technology (NIST) Task Force on smart grid standards focused on this issue.<sup>17</sup>

Well-designed data exchange and access policies facilitate **innovative uses of electricity consumption data**. Third parties can use APIs, standardised data formats and communications protocols to create value-added services for utilities and consumers. Utilities can use advanced data mining to improve their products and services offered; customers can benefit from improved information to adjust electricity use patterns. A start-up in the United States, OPower, built a business model around the analysis of metering data and other data sources.<sup>18</sup> Its software provides utilities ways to communicate potential energy savings to customers and compare electricity use with that of peers, *e.g.* the neighbourhood (see Figure 11). Communications channels include web portals, mobile applications and SMS but also paper-based “energy-use” reports that complement electricity bills. According to preliminary research, use of the data analysis software can achieve sustained systemic reductions of around 3% across a utilities’ network, which can be sufficient to avoid the need to further increase installed capacity for meeting peak demand (Allcott, 2009; Ayres *et.al.*, 2009). Again, design issues are relevant: the frequency of reporting, choice of communications channel and information provided impact on the levels of savings achieved.

**Figure 11. Metering data used in consumer energy reports**

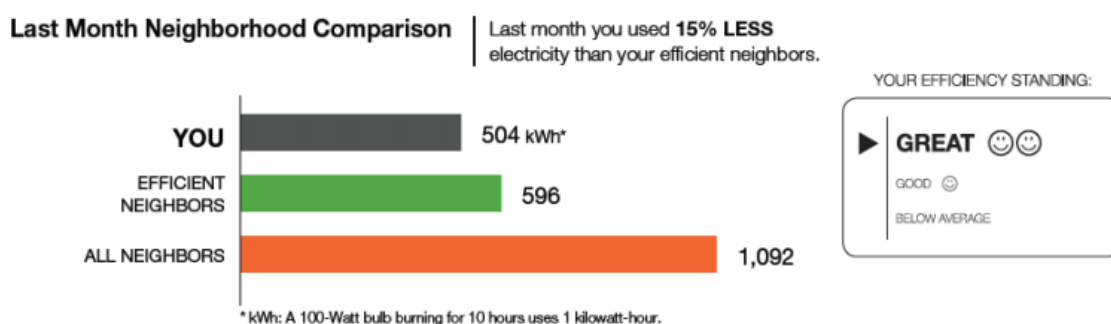

**Action Steps** | Personalized tips chosen for you based on your energy use and housing profile

Quick Fixes	Smart Purchases	Great Investments
<p>Things you can do right now</p> <p><input type="checkbox"/> <b>Adjust the display on your TV</b> New televisions are originally configured to look best on the showroom floor—at a setting that’s generally unnecessary for your home.</p> <p>Changing your TV’s display settings can reduce its power use by up to 50% without compromising picture quality. Use the “display” or “picture” menus on your TV: adjusting the “contrast” and “brightness” settings have the most impact on energy use.</p> <p>Dimming the display can also extend the life of your television.</p> <p><b>SAVE UP TO \$40 PER TV PER YEAR</b></p>	<p>Save a lot by spending a little</p> <p><input type="checkbox"/> <b>Install occupancy sensors</b> Have trouble remembering to turn the lights off? Occupancy sensors automatically switch them off once you leave a room—saving you worry and money.</p> <p>Sensors are ideal for rooms people enter and leave frequently (such as a family room) and also areas where a light would not be seen (such as a storage area).</p> <p>Wall-mounted models replace standard light switches and they are available at most hardware stores.</p> <p><b>SAVE UP TO \$30 PER YEAR</b></p>	<p>Big ideas for big savings</p> <p><input type="checkbox"/> <b>Save money with a new clothes washer</b> Washing your clothes in a machine uses significant energy, especially if you use warm or hot water cycles.</p> <p>In fact, when using warm or hot cycles, up to 90% of the total energy used for washing clothes goes towards water heating.</p> <p>Some premium-efficiency clothes washers use about half the water of older models, which means you save money. SMUD offers a rebate on certain washers—visit our website for more details.</p> <p><b>SAVE UP TO \$30 PER YEAR</b></p>

Source: Company information by Opower, reproduced in Alcott, 2009.

### ***Demand management***

*Ad hoc* demand management complements smart grid strategies to minimise the environmental impacts of electricity consumption. Structural moves towards energy conservation, as discussed above, can limit longer-term growth in demand and thereby reduce the need for increased “baseload” capacity. Nevertheless, electricity systems in OECD countries will continue to experience periods of unusually high electricity demand. In some cases, peak demand can be double the amount of minimum electricity demand in one country (see Box 1 for an explanation of peak demand). Load fluctuations put pressure on utilities and grid operators to minimise differences in supply and demand because high voltage differences mean a degradation of power quality and can eventually cause black-outs. Moreover, peak demand increases environmental burdens because it operationally means resorting to back-up power plants, which typically run on the combustion of fossil fuels and thereby greatly increase pollution from electricity generation.

“Load balancing” today happens primarily *via* supply-side adjustments, whereas demand-side opportunities remain underexploited. Electricity suppliers have for a long time used sophisticated methods to estimate near-future grid loads and correspondingly adapt electricity production across different sites as well as trading electricity across national borders. Direct response actions on the demand side (called peak shaving) have so far been largely limited to industrial customers with volume contracts that sometimes include provisions for reacting to sudden grid load increases. This approach has its limitations, however, given that some industrial processes are harder to turn on or off than others without risking significant under-utilisation of assets due to power-up and cool-down times; in other instances financial incentives for lowering the output of a factory in return for pay-back by the utility might simply not be sufficient. Demand management is therefore expanding rapidly to encompass further commercial and residential customers.

**Smart meters** expand the potential impact and customer base for automated and mediated demand management. An automated metering infrastructure (AMI) is key for effective peak demand management, particularly when coupled with dynamic pricing schemes and “smart” electrical appliances. Improved information about the current supply of electricity, its price and environmental impacts can help *residential consumers* shift the timing of certain activities, *e.g.* operating dishwashers and washing machines, charging the electric vehicle. Information can be effectively visualised through web and smartphone interfaces, but also through traditional, paper-based reports for end consumers. *Commercial and public sector customers* have some discretion over building operations. Price or other signals can be used to adjust electricity use of HVAC (heating, ventilation, air conditioning), lighting and IT infrastructures. In the case of larger *commercial and industrial customers*, demand responses often also include resorting to off-grid electricity use, *i.e.* using on-site back-up generators, although this does not necessarily reduce greenhouse gas emissions.

Some types of demand responses can be automated for greater impact and efficiency. The smart meter and other IP-based devices then function as an interface between the utility, its customers and “**smart building**” technologies. Home automation and advanced buildings management systems (BMS) allow customers to set up “profiles” that are activated when a price or availability signal is received from the utility. Many utilities offer rebate systems to customers willing to reduce electricity demand at peak times. Potential savings are very high in commercial and industrial sectors – Cisco’s automated demand response system at IT service provider NetApp allows the company to reduce grid load by over 1 MW within minutes and thereby receive paybacks of up to USD 5 000 per event.<sup>19</sup> Actually, IT service and Internet companies have a much greater potential to achieve monetary and environmental benefits by actively engaging in demand management for large distributed IT infrastructures. Cloud computing in particular can offer great opportunities in this area as shown in Box 2.<sup>20</sup>

Future-proofing of **communications interfaces** (*i.e.* protocols) is important for automated demand response. This is in analogy to the earlier discussion of smart meters for energy conservation. Communications interfaces need to be able to exchange information with existing as well as future electrical devices and BMS. Standards are necessary to accommodate the information requirements of utilities, aggregators, regulators and end consumers in this area. However, the lack of empirical evidence on the advantages of automated demand response as well as concerns about privacy can be a hindrance to wider uptake: a German survey found that automated control of household appliances is considered the least of nine possible advantages for consumers (Forsa, 2010).

### Box 2. Cloud computing for effective peak demand management

Cloud computing service providers are becoming important participants in the electricity market. That is because global Internet trends drive the need for data computing, storage and communications. These needs are satisfied through increases in communications networks, servers and data centres. At a macro level, the latter two categories alone are estimated to represent 2% of global electricity consumption. At a company level, Google as an example of a major cloud service provider accounts for roughly 0.06% of annual electricity production in the United States. In other words, the company is close to consuming one unit of power for every 1 000 units generated in the country.

Data centres are a major part of the equation in dealing with surging electricity demand. Grid loads of individual data centres illustrate their emergence as “digital factories” in the 21<sup>st</sup> century: whereas most data centres have a maximum load of 10 MW, larger and newer data centres are coming close to or hitting the 100 MW barrier (e.g. Next Generation Data, Newport, United Kingdom; Lakeside Technology Center, Chicago, United States; QTS Metro Data Centre, Atlanta, United States). The term “digital factories” seems appropriate because of loads that are comparable to those of industrial processes; an aluminium smelter’s typical load for example starts at 150 MW.<sup>21</sup> At the same time data centres are very much unlike traditional factories because IT services are much more flexible and can help actively manage supply and demand fluctuations on the electricity grid. This, in turn, can help lower the greenhouse gas emissions related to electricity production. Remedying actions include technological fixes to adjust HVAC, lighting, but also computing resources “on the fly”.

A more structural approach to addressing greenhouse gas emissions from surging electricity demand could be the strategic use of cloud computing. Its main advantage is that it allows geographic decoupling of demand and supply for computing services. It allows dynamic allocation of computing and storage resources without worrying about where the data is travelling from/to (latency and legal requirements aside). Major IT service companies typically run data centres at more than one geographical location. Global Switch, for example has a network of eight data centres in Europe, Asia and Australia with grid loads of up to 45 MW (London data centre). Stakeholders from the IT and energy sectors could jointly develop response schemes for critical times of peak electricity demand. This can include routing non-critical requests to global data centre locations that have sufficient electricity supply.

Environmental benefits of such co-ordinated action can be high. Peak electricity demand is typically satisfied using power plants that generate electricity from coal, gas or oil. Average capacities of these plants in the United States are: 235 MW, 84 MW and 17 MW, respectively. This means that a significantly lower electricity load from *one* data centre alone could make one or more fossil-fuel based power plants obsolete for meeting peak demand.

Benefits can be even higher around urban areas, where many data centres are built for business and technical reasons. Cities have high total volumes of electricity consumption. Peak demand therefore creates relatively high pressures on the grid (and thus the environment). The role of cloud computing can be illustrated by looking at Germany’s major cities, Hamburg and Berlin, that have maximum grid loads of between 2 to 2.5 GW. This means the load of only *one* 100 MW data centre can equal up to 5% of a large German city’s peak electricity demand. Obviously, an entire data centre cannot be turned off so a 5% shedding of load is not technically feasible. Nevertheless, the comparison provides an order of magnitude for potential peak demand reductions that advanced IT services such as cloud computing can enable.

A major policy challenge to realise this potential will be the attribution of emissions savings and the creation of incentives. Depending on the design of carbon accounting (and billing) schemes, cloud service providers’ efforts to reduce peak demand may or may not be attributed to their activities, *i.e.* may or may not pay off financially.

*Sources* : Company information and OECD, 2010a (for electricity footprint of the Internet); US EIA, 2010 (for average power plant capacities); Greenpeace, 2010; Ghatikar *et.al*, 2010 (on demand response for data centres); publicly available information from companies Google, Next Generation Data, Digital Reality Trust, Global Switch, QTS, Vattenfall.

### *Integration of electric vehicles (and renewable energy sources)*

Electric vehicles are considered a prime option to reduce greenhouse gas emissions from transport as well as deal with volatile prices and availability of oil. Transport emissions have grown rapidly in the past decades, topped only by growth in emissions from electricity production (see Figure 2). As sales of plug-in

electric vehicles (PEVs) are accelerating with mass-produced cars entering markets in 2011 (*e.g.* Chevrolet Volt, Nissan Leaf, Renault ZE), this will alter existing supply and demand structures around electricity. The IEA estimates that by 2020 over 7 million electric vehicles (PHEVs and EVs) will be sold annually worldwide. There is a risk that the adoption of electric vehicles will increase the strains on electricity supplies and networks that in many countries already are close to capacity, efficiency gains and rebound effects aside. Evidently, the environmental performance of electric cars depends largely on the supply of electricity from non-polluting energy sources. Finally, growing demand for certain raw materials and rare metals, primarily lithium, to satisfy demand by battery producers is likely to have significant environmental impacts during production and end-of-life. Concentration of lithium in a few geographical zones (Argentina, Australia, Bolivia, Chile and China) can create supply and price risks in the long term (see OECD, 2010a).

The environmental and commercial success of the electric vehicle will be a function of individual and systemic variables. On the micro level, consumers will mainly compare affordability, comfort and operating costs with those of traditional cars. On the macro level, electric vehicles will be measured in their contribution to lower transport-related greenhouse gas emissions, reduced road congestion and smooth integration with existing installed capacities for electricity production. Other stakeholder interests can be the source of further trade-offs (see Figure 12).

**Figure 12. Stakeholder interests in operating electric vehicles**

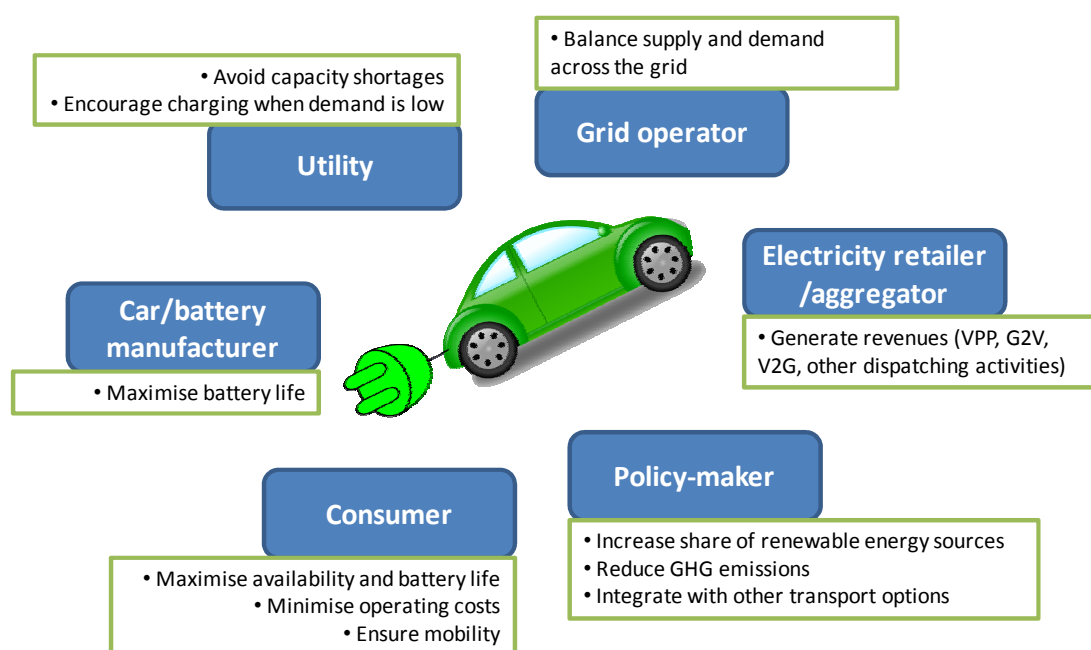

“Smart” approaches to managing the wider introduction of PEVs are necessary, in particular for the exchange and analysis of information about the use patterns for vehicles, but also for billing and overall traffic management. Innovative use of ICTs and the Internet can help accommodate trade-offs and implement preferences of stakeholders accordingly. Prioritisation of these preferences (*e.g.* policy maker vs. consumer) is a matter of politics. Implementation of the preferences, however, greatly depends on integrated IT systems that are able to use the large amounts of data and preferences compiled from utilities, grid operators, manufacturers, consumers and policy makers. A project such as Better Place could not “square the circle” of a successful EV infrastructure without an integrated software system and highly sophisticated algorithms.<sup>22</sup>

From a **consumer** point of view, availability is a prime concern for the electric vehicle. This refers to short-term availability of the vehicle (“range anxiety”) as well as sustained high battery performance after several years of using the electric vehicle. To improve availability and comfort, end-user interfaces allow setting up of use “profiles” for the car, *e.g.* times when it needs to be available. Other options can include preferences for charging/discharging and benefitting from monetary incentives for electricity use and storage. Interfaces can be implemented using the smart meter, but can also refer to separate software, Internet or mobile applications. Automated data sharing, *e.g.* with personal or corporate calendar applications, can further enhance its usefulness for the end user. Open standards for data exchange will be essential in order to avoid lock-in and interoperability issues when changing cars or connected devices. They moreover permit the use of non-proprietary end user devices for controlling EV charging. However, the protection of personal preferences from access by unauthorised parties is a crucial question to address. Data access, communications and storage policies need to be defined during the design phase of a system that directly links consumer preferences, vehicle (use) information and third-party systems.

Consumers will weigh operating costs against financial and possibly non-monetary benefits when considering purchase of a PEV. Depending on use patterns, the use of an electric car can increase a household’s electricity bill up to threefold.<sup>23</sup> The question is whether some of these costs can be compensated by savings in fuel as well as potential reductions as part of electricity storage and feed-back schemes (G2V, V2G, V2H). But non-monetary benefits can change consumer perception too, by, for example, providing more seamless integration of the PEV with other transport options. PEVs require built-in access to communications networks and they typically have advanced user interfaces to inform users of charging state, range, navigation options. These interfaces can be used to provide advanced and non-proprietary services.

Mash-ups, smartphone applications and innovative software have the potential to blur boundaries between different transport options such as one’s own car, mass transport and car sharing. Complemented with data such as weather information, mood indicators, personal preferences and social networking information, Internet-based technology will greatly enhance the utility of EVs. Integrated infrastructure projects such as Better Place (Israel, Denmark) or Mobi.E (Portugal) work on developing systems for advanced mobility where seamless integration of real-time information on the vehicle, user preferences, context and available transport options puts the user’s transport purpose at the centre. At the same time, access to and treatment of data has to be guided by strong policies to protect personally identifiable and other confidential information from undesired or unlawful exploitation by third parties.

From a **utility** point of view, optimal utilisation of installed assets represents a challenge in rolling out the electric car more widely. Expansion of capacities, *i.e.* commissioning of new power plants, represents challenges in terms of investment as well as public opinion; “not in my backyard” attitudes are problematic in this regard. Utilities therefore prefer to ensure that the electric vehicle will not lead to electricity capacity shortages, notably by using “controlled charging” to exploit off-peak electricity supply. A study for New York City shows that such controlled charging is necessary in order not to strain capacities. The charging of electric vehicles at times when other demand is low (*i.e.* primarily at night) is the only way that

significant infrastructure expansion can be avoided.<sup>24</sup> Controlled charging requires co-ordination of stakeholders' interests (see Figure 12) as well as integrated IT systems and communications channels for the actual implementation. Status information, price and control signals can be sent and received by IT systems of utilities, grid operators or third parties plus the electric vehicle itself, smart meters, software on the Internet and mobile applications. If annual EV sales will indeed reach 7 million by 2020, non-proprietary interfaces and communications protocols will be essential for success. This does not mean, however, that *one* open standard has to prevail. Communication devices should be able to support multiple protocols so that service providers can choose the ones most suitable for a given set of requirements (see Tuttle and Baldick, 2010).

Finally, **policy makers** constitute an important stakeholder group for which success will be largely measured in terms of promoting renewable energy sources to operate EVs and integrating them into wider transportation policy goals, *e.g.* to reduce road congestion. Advanced IT systems are key to enabling a smooth integration between renewable energy sources and EVs; this includes integrated accounting systems and charging infrastructures, communications with local network stations, controlled charging, active battery management and provision of ancillary (*i.e.* value-added) services (see RETRANS, 2010). Policy makers can facilitate co-ordinated research and implementation agendas through support for cross-sector pilot projects. Moreover, they have a role to play in formulating requirements for the resilience and security of these IT-based systems. In some sectors, meeting the increasing demand for IT experts with operational knowledge in electricity and transport can become a challenge and might require updating engineering and IT education curricula.

Coherence of EVs agendas with transport policy goals is important to tackle transport challenges. Road congestion, for instance, is a growing concern across OECD countries. Integrated communication interfaces allow EVs to exchange data with other vehicles as well as third-party service providers. There is great potential for innovative approaches to sharing information about users, vehicles, transport options and travel purposes in order to propose suitable options for getting from point A to B.<sup>25</sup> Innovative end-user interfaces include the use of smartphone applications (apps) to provide detailed information about immediate transport options, duration of travel, economic and environmental costs. They can help consumers make informed choices about transport options and they can help policy makers in better managing transport and optimising the utilisation of public assets.



## POLICY IMPLICATIONS

### Overarching challenges for policy makers

A key message underlying this report is that innovation drives the development of the smart grid. The smart grid is expected to help achieve levels of electricity production that are sustainable in the long run, that reduce environmental burdens, but that also permit individuals to maintain or improve standards of living.

Policy makers have some options at hand to facilitate “green innovation” and transformational change through the use of ICTs in the electricity sector (OECD, 2011*b*). Diversification towards sustainable energy sector products, services and infrastructures can be achieved through *i) market mechanisms*, e.g. for transparency and access to information for all value chain participants, *ii) financial incentives*, e.g. contribution to investment costs or tax breaks for infrastructure investments, *iii) targeted regulation*, e.g. the recent EU Directives mandating a roll-out of smarter electricity meters that *inter alia* provide improved information to final customers (2006/32/EC and 2009/72/EC). Governments can also facilitate innovation “spill-overs” from the ICT to the energy sector and related industries such as transport and construction. Ways to do so include promoting R&D and commercialisation overall, reducing barriers to entry for smaller enterprises, supporting cross-sector technology development and diffusion and co-ordinating national policy agendas for energy, IT and communications (see OECD Council Recommendation on ICTs and the Environment, 2010*b*).

Despite existing success stories in promoting innovation, significant challenges remain for the wider transformation towards smart grids. The following challenges are overarching in nature, *i.e.* they do not regard solely policy makers with IT and telecommunications portfolios. But they provide the context for a closer look at ICT-specific policy challenges following thereafter.

- **Information and communication:** Information asymmetries across the electricity sector value chain remain an important issue to tackle, and with them the need for effective and reliable communications channels. The electricity sector’s “line of command” in cases where electricity demand risks peaking (e.g. extremely hot or cold days) remains to a large degree patchy and mediated. Final electricity consumers, in particular residential consumers, have little effective means of obtaining information about the current state of electricity production, its availability, cost and environmental impacts. Press releases issued by utilities about upcoming peaks may or may not be picked up by the local media and customers may or may not pay attention to aggregate information about the electricity system and its state. Direct messages over digital communications channels, especially when linked with customer-specific information and advice, represent “low-hanging fruit” as far as communication channels are available.

Information asymmetries also affect upstream processes. Utilities have relatively little information about disaggregated electricity consumption patterns below the distribution system level and losses of electricity along transmission and distribution lines are not always accounted for systematically.

- **Economic and financial hurdles:** High investments in research, development and deployment (or RD&D) are necessary to modernise national electricity systems. National grid assets in OECD countries are often several decades old and function close to maximum capacity. In many emerging economies electricity infrastructures are “greenfield” investments – this means more advanced technological levels from the start but it requires higher investments too.

Overall, the IEA estimates that maintenance and expansion of transmission and distribution networks globally will require investments of over USD 8 trillion between 2010 and 2050 (this excludes investments in power generation). Making these grid investments “smart” would add at least USD 3 trillion to the bill (IEA, 2010*b*). Looking at closer horizons, needed investments are estimated at around USD 600 billion in Europe by 2020 and close to USD 500 billion in the United States by 2030.<sup>26</sup> Although proponents of the smart grid point out substantial returns on investment, concerns also exist that some purposes of the smart grid (*e.g.* energy efficiency and conservation) might not be consistent with business models that are traditionally based on volume sales. Large-scale investments are also at risk from low and falling levels of private and public-sector spending on energy R&D over the past decades. Despite ambitious political agendas in this area, expenditures are unlikely to rise substantially, reflecting the impact of the economic crisis and tightening public budgets.

- **Consumer acceptance, engagement and protection:** Improved information on energy use and better access to it can bring substantial social, economic and environmental benefits. Mediated or automatic control of electric devices can help manage electricity demand *and* lower electricity bills. Benefits of the latter sort can be of particular importance to low-income groups spending relatively large parts of their household income on energy.

However, trial outcomes on electricity demand and costs are ambiguous. Various survey results show that consumers are concerned about privacy issues and costs related to smart meters. These concerns need to be addressed when designing products and services from the start, otherwise public opinion risks turning against smart grid initiatives. The smart meter, for example, provides valuable information, but it also adds a level of complexity to an area of consumption that so far used relatively simple tariff structure (*c.f.* Consumer Focus, 2010). Dynamic pricing of electricity will change that, making electricity prices dependent on levels of electricity supply, demand and their environmental impacts. These changes are necessary, but they will require well-designed interfaces between the user and the technology. And it requires behavioural changes that can come about through guidance and education.<sup>27</sup>

Consumer concerns around the smart grid focus also on electricity provision to poorer and vulnerable parts of the population. Consumer rights groups highlight that smart meters potentially lower the operational barriers for utilities wishing to remotely turn off electricity supply or switch customers to more expensive pre-paid tariffs (*c.f.* Consumer Focus, 2010). It therefore seems necessary to meet these new technical possibilities with improved legal and other safeguards for concerned customers. Otherwise, the smart meter risks facilitating wider diffusion of controversial business practices.

Finally, the question of who bears the initial costs of smart meter deployments is causing substantial debate among utilities, consumer associations and policy makers. The costs per installed meter are estimated to be around USD 500, including the required ICT infrastructure in the “back-end”.<sup>28</sup> The role of the customer in supporting this cost is far from clear.

## ICT-specific policy implications

Policy implications that are of specific relevance to ICT policy makers and telecommunications regulators include:

### *Regulatory and networks issues*

- **Converging energy and telecommunications services.** The report shows that energy and telecommunications services are increasingly intersecting. The smart meter is a prime example of smart grid technology that blends electricity provision and consumption with advanced communication requirements. There is a potential need for open access provisions allowing smart meter service providers and utilities access to data capacity over telecommunications networks. But converging trends go further than that to encompass emerging bundled offers for telecommunications and utility services: Australian utility ActewAGL offers “sextuple-play” services made up of electricity, gas, voice, data, TV and mobile; in the United States, the merger of Hancock Telecom and Central Indiana Power offers customers energy and communications services, complemented by value-added services for home automation and security. Policy makers and regulatory authorities in OECD countries have started consultations on the communications needs for the smart grid (*e.g.* by DoE) and integrating energy policy objectives into national broadband plans (*e.g.* FCC). But these are only the first signs of greater convergence of the two regulatory areas. Increased services bundling might require enhanced co-ordination between regulatory authorities. Co-ordination could in some instances be challenging given that the regulatory domains of energy and telecommunications are traditionally located with separate institutions (exception: Germany’s Bundesnetzagentur, BNetzA).
- **Connectivity.** Communication channels need to be available across the economy to all electricity users to maximise the potential benefits of smart grids. Ensuring communication channels are available universally across the economy will remain a key goal of policy makers and there are significant potential synergies that could be exploited between communication and electrical distribution companies (*e.g.* utility pole or duct sharing). Increased reliance on communication networks in the electricity sector will put to test existing infrastructures regarding speed, quality of service and equal treatment of competitors’ information. Although the need for real-time communications links along the electricity sector value chain is likely to be an exception, fast response times are nevertheless necessary to simultaneously send control signals to virtual power plants that can comprise hundreds, or even thousands of individual entities. The number of connected devices could grow by orders of magnitude if projections for annual sales of electric vehicles (7 million worldwide in 2020) and mandated smart meter installations are realised (around 180 million in Europe in 2018).<sup>29</sup> Utilities, grid operators and 3<sup>rd</sup> party intermediaries will depend on efficient network infrastructures to control the charging (grid-to-vehicle) and discharging (vehicle-to-grid, vehicle-to-home) of electric vehicles. Bandwidth requirements are difficult to estimate. On the one hand, data traffic will predominantly cover status information and control signals, which can be designed for reduced size. On the other hand, the sheer amount of connected entities and devices that will have to communicate simultaneously in smarter grids could require significant bandwidth. Finally, there are possible needs for more spectrum for wireless data exchange.
- **Interoperability.** Open standards for communications protocols are important to enable innovation. Especially for long-lived assets in the electricity sector, communications capabilities should include multiple protocols so that service providers can choose the ones most suitable for a given set of requirements. IP-based infrastructures will allow the exploitation of future synergies between electricity, transport and buildings management applications as well as other

areas such as healthcare and education. Interoperability is furthermore necessary to ensure fair competition and to avoid the “lock-in” of customers into proprietary systems of utilities, aggregators or other third-party service providers.

- **Two-sided markets.** Aggregators and virtual power plant operators cater to utilities and final customers alike. Their market power depends on the rebates they can achieve with utilities (in general, larger customers get higher rebates) and the number (and type) of customers they can aggregate. In a typical two-sided-market situation, the higher the number of customers, the higher the rebates; the higher the rebates, the more customers will be attracted. As in other two-sided markets (*e.g.* advertising), some consideration might be necessary on the potential concentration effects for some types of value-added electricity services.
- **Potentially adverse health impacts.** A general concern related to wireless technologies, health impacts from potential increases in electromagnetic radiation, is also emerging in relation to smart meters (see Forsa, 2010). While empirical evidence remains ambiguous about the long-term impacts, it might be desirable to allow customers to selectively turn off wireless data transmission, *e.g.* at night, or potentially default to wired infrastructures when available.

### *IT and IT sector issues*

- **Innovation and value-chain disruption.** A number of ICT companies are providing entirely new services or services formerly reserved to utilities only. It is therefore important for incumbent stakeholders to define and formulate requirements and for newcomers to be able to engage in cross-industry dialogue. Successful IT firms appear to be able to listen carefully to electricity sector requirements while at the same time leveraging the innovation potential that ICTs and the Internet provide. Opower is an example that uses electricity data to provide intelligence to utilities and customers; Silver Spring Networks is a networking company that focuses on smart grids; Better Place is a mediator between the different stakeholder interests in the electric car; Genspace intermediates information exchange between electricity market participants. Policy makers can reinforce this alignment through co-ordinated pilot projects that involve utilities, IT firms and other stakeholders (example: German “e-Energy” pilot projects), by highlighting the importance of joint research and implementation agendas (*e.g.* EC, 2010) and by improving framework conditions for entrepreneurship and access to funding for innovative start-ups (*c.f.* OECD, 2011a).
- **Converging “vertical” industries and sectors.** The report shows that ICTs, and the Internet in particular, lead to ever-more touching points between the electricity, transport and buildings sectors. The smart meter is likely to become a central node facilitating the provision of electricity, the efficient management of EVs, the control of individual household appliances or entire buildings management systems, and the integration of renewable energy sources. Although the smart meter will likely remain a physical hardware device, many of its functions will be accessible via Internet-enabled PCs, tablets and smartphones. Integration is unlikely to stop at the mentioned industry sectors, but could encompass functions related for example to healthcare and wellness (*e.g.* applications tracking time spent driving vs. time spent walking).
- **Converging IT and operational technologies (OT).** The use of IT is not new to the electricity sector. However, a change is taking place in the quality of engagement between utilities and ICT firms. IT firms that want to provide value-added services in the smart grid need a more detailed understanding of operational processes. This refers to services targeting utilities (*e.g.* distribution grid management), consumers (*e.g.* energy consumption optimisation), or both (*e.g.* operating virtual power plants). The trend can be described as converging IT and operational technologies

(OT).<sup>30</sup> The ever-tighter integration of IT into operational processes in the electricity, transport and buildings sectors requires the alignment of research and policy agendas. Co-ordinated approaches are important to drive innovation (see above), but also to make ICT applications relevant to the challenges of making electricity supply efficient, reliable and sustainable.

- **Emerging skills requirements.** Immediate skills needs are accelerating at the same time as some OECD countries are noticing declining attraction of students to so-called STEM subjects (science, technology, engineering, mathematics). This could trigger shortages when smart grid developments accelerate. Moreover, the growing need for an operational understanding of electricity, transport and buildings management might require adapting curricula for engineering courses and other IT-oriented education programmes (*c.f.* OECD, 2010c, Chapter 3). Implementation of smart grids projects will require field-specific knowledge of legal frameworks, environmental impacts, etc.
- **Interoperability.** Open standards for data exchange will be essential in order to avoid the lock-in of customers or interoperability issues, *e.g.* when switching electric vehicles or service providers. Open standards can spur innovation, *e.g.* by making certain functions available on non-proprietary end user devices. The integration with development platforms for mobile phones, *e.g.* iPhone and Android, can make management and control of electricity more accessible for individuals. Well-defined APIs are likely to enable a flux of innovative services developed for specific end-user needs that might not necessarily be identified or provided by utilities and grid operators.
- **Future-proof design and upgradeability.** Discrepancies between innovation cycles in the ICT and electricity sectors require long-lived assets to be designed in ways that will not render them obsolete in the face of innovation. Once installed, electricity meters are expected to remain in place for decades; applications, devices and networking technologies, however, constantly evolve. It is therefore important to ensure interoperability with widely-used communications and data access protocols (see above). Design choices should allow for remote upgrades to firmware instead of on-site manipulations.

### *Security, resilience, privacy and exploitation of personal data*

- **Risks of converging IT and OT.** Closer integration of large-scale operational systems with IP-based networks such as the Internet increases the openness of critical infrastructures. The StuxNet worm and its impact on targeted industrial systems is only one example of the potential threats. Operational systems that exchange data with IP-based networks need to be designed for security and resilience. Critical infrastructures converging with information infrastructures require scenario-building that includes consideration of highly unlikely types of events. Moreover, IT security considerations need to be integrated within the wider risk management framework of the organisation or the operational system.<sup>31</sup>
- **Upholding availability, integrity, confidentiality and authenticity.** The smart meter is likely to become a key node for managing information about the electricity system (*e.g.* grid loads) and about final customers (*e.g.* preference “profiles” for charging of electric vehicles). Questions must be addressed about unauthorised access to electricity data, the prevention of “malware” in the smart meter and connected devices and other potential security threats. Trends towards greater automation and remote control need to be accompanied by policies that can guarantee integrity and authenticity of information. The smart meter will send and receive control signals that directly impact the functioning of associated devices, *e.g.* electric vehicles, domestic appliances and small-scale energy generators. In many cases, wireless communications channels

will be used for short-distance communications (*e.g.* Wi-Fi, ZigBee, Bluetooth) as well as for long-distance communications (*e.g.* with mobile phones over 3G and 4G networks). Availability, integrity and authenticity therefore need to be assured across the entire “value chain” of the control signal. This includes pricing information sent by utilities, capacity information sent by grid operators, control signals sent by aggregators and virtual power plants operators. But it also includes communications channels that enable exchanges of information between the smart meter and connected devices.

- **Personal data access, possession and ownership.** The economic value of personal data is rapidly increasing, both in personally identifiable and aggregated forms.<sup>32</sup> Safeguards are necessary to prevent the illicit use of certain data for commercial and criminal purposes. Privacy protection principles need to be adhered to when designing smart grid projects, including domestic legislation and international policy instruments.<sup>33</sup> A pivotal point will be to integrate privacy principles for personal data from the project outset (“privacy by design”), *e.g.* through privacy impact assessments and a minimisation of personal data processing.<sup>34</sup> Furthermore, early involvement of consumers and consumer associations is important in order to generate “buy-in”. Surveys of consumer opinion show that privacy issues are of major concern and have the potential to steer the public debate on smart grids and smart metering in ways that would overshadow many of the socio-economic benefits (*e.g.* Forsa, 2010). In more general terms, access, ownership and disclosure principles for metering data will need to be clarified. Regulation in various countries, for example, requires that personal data be distinguished from non-personal data because of the limitations on what utilities and grid operators are allowed to do with personal data without prior consent by consumers. Possession, *i.e.* storage, of personal data needs to be guided by precautionary principles because trends in this paper imply a growing number of parties interested in exploiting the business potential of access to personal data, *e.g.* aggregators, applications developers, IT service providers. Finally, ownership (and interoperability) questions need to be addressed to avoid lock-in of customers to specific utilities and service providers. In this context, should there be “opt-out” clauses whereby customers can choose not to engage in schemes for remote control? In that case advanced functions of the smart meter would have to be limited to local applications only. Development and implementation of effective policies in these areas require co-ordination with user associations, consumer protection and law enforcement agencies.

**NOTES**

## REFERENCES

- Allcott, H. (2009), “Social norms and energy conservation”, MIT working paper.
- Ayres, I., Raseman, S. and A. Shih (2009), “Evidence from Two Large Field Experiments that Peer Comparison Feedback can Reduce Residential Energy Usage”, paper presented at the *5th Annual Conference on Empirical Legal Studies*.
- Blackburn, J. (2010), “Matching Utility Loads with Solar and Wind Power in North Carolina: Dealing with Intermittent Electricity Sources”, Working paper, Institute for Energy and Environmental Research, MD, United States.
- Consumer Focus (2010), “Consumer Focus response to Smart Metering Implementation Programme: Consumer Protections”, October.
- Darby, S. (2009), “Smart metering: what potential for householder engagement?”, *Building Research and Information*, Vol. 38, No. 5, pages 442-457.
- Dennis, M. and B. Thompson (2009), “Vehicle to grid using broadband communications”, *Telecommunications Journal of Australia*, Vol. 59, No. 1.
- EDF (2010), “Vague de froid : EDF mobilise tous ses moyens de production disponibles et l'ensemble de ses équipes”, press release, 1 December, <http://medias.edf.com/communiqués-de-presse/tous-les-communiqués-de-presse/communiqué-2010/vague-de-froid-edf-mobilise-tous-ses-moyens-de-production-disponibles-et-l'ensemble-de-ses-equipes-82418.html>, last accessed 2 May 2011.
- Ehrhardt-Martinez, K., K. Donnelly and J. Laitner (2010), “Advanced Metering Initiatives and Residential Feedback Programs : A Meta-Review for Household Electricity-Saving Opportunities”, Report for the American Council for an Energy-Efficient Economy (ACEEE).
- European Commission [EC] (2010), *Energy 2020 - A strategy for competitive, sustainable and secure energy*, Communication, 10 November.
- FENIX (2008), “The Economics of FENIX Virtual Power Plant”, Project bulletin No. 4, June.
- FENIX (2009a), “What is new in FENIX for network operators?”, Project bulletin No. 8, May.
- FENIX (2009b), “The FENIX Scenarios – Outlines of the Southern Demonstration”, Project bulletin No. 6, January.
- Forsa (2010), “Erfolgsfaktoren von Smart Metering aus Verbrauchersicht”, report commissioned by Verbraucherzentrale Bundesverband (Federation of German Consumer Organisations), Forsa, Berlin.
- Ghatikar, G. *et al.* (2010), “Demand Response and Open Automated Demand Response Opportunities for Data Centers”, working paper for the California Energy Commission, PIER Program and Pacific Gas and Electric Company (PG&E).
- Greenpeace (2010), “How dirty is your data? A look at the energy choices that power cloud computing”, 20 April.



- Inage, S. (2009), “Prospects for large-scale energy storage in decarbonised power grids”, IEA Working Paper, IEA, Paris.
- International Energy Agency [IEA] (2010a), *Electricity Information, 2010*, OECD/IEA, Paris.
- International Energy Agency [IEA] (2010b), *Energy Technology Perspectives 2010. Scenarios and strategies to 2050*, IEA, Paris.
- International Energy Agency [IEA] (2010c), *World Energy Outlook 2010*, IEA, Paris.
- International Energy Agency [IEA] (2011), *Technology Roadmap. Smart Grids*. IEA, Paris.
- Intergovernmental Panel on Climate Change [IPCC] (2007), *Contribution of Working Group III to the Fourth Assessment Report of the Intergovernmental Panel on Climate Change*, edited by B. Metz, O.R. Davidson, P.R. Bosch, R. Dave, L.A. Meyer; Cambridge UP, Cambridge.
- Major Economies Forum [MEF] (2009), *Technology Action Plan: Smart Grids*, MEF, Washington, DC.
- OECD (2008), *OECD Environmental Outlook to 2030*, OECD, Paris.
- OECD (2009a), *Smart Sensor Networks: Technologies and Applications for Green Growth*, OECD, Paris, [www.oecd.org/dataoecd/39/62/44379113.pdf](http://www.oecd.org/dataoecd/39/62/44379113.pdf).
- OECD (2009b), “Towards Green ICT Strategies: Assessing Policies and Programmes on ICT and the Environment”, OECD, Paris, [www.oecd.org/dataoecd/47/12/42825130.pdf](http://www.oecd.org/dataoecd/47/12/42825130.pdf).
- OECD (2010a), “Greener and Smarter. ICTs, the Environment and Climate Change”, OECD, Paris, [www.oecd.org/dataoecd/27/12/45983022.pdf](http://www.oecd.org/dataoecd/27/12/45983022.pdf).
- OECD (2010b), *OECD Council Recommendation on ICTs and the environment*, 8 April, C(2010)61.
- OECD (2010c), *OECD Information Technology Outlook 2010*, OECD, Paris.
- OECD (2011a), *Towards Green Growth*, OECD, Paris.
- OECD (2011b), *Fostering Innovation for Green Growth*, OECD, Paris.
- OECD (forthcoming), “Machine-to-machine communications: connecting billions of devices”, DSTI/ICCP/CISP(2011)4.
- OFGEM (2010), “Energy Demand Research Project (EDRP). Fifth progress report”, Ref. 163/10, 20 December.
- RETRANS (2010), *Opportunities for the Use of Renewable Energy in Road Transport. Policy Makers Report*. March. Report for the IEA Renewable Energy Technology Deployment (IEA-RETD) project.
- Stuart Young Consulting (2011), “Analysis of UK wind power generation. November 2008 to December 2010”, Stuart Young, Dunnet.
- Tuttle, D. and R. Baldick (2010), “The Evolution of Plug-in Electric Vehicle-Grid Interactions”, 26 November, University of Texas at Austin, Austin, Texas.

United States Energy Information Administration [US EIA] (2011), *Electric Power Annual. Data for 2009*, revised version of April.

United States Federal Energy Regulatory Commission [US FERC] (2009), “A national assessment of demand response potential”, report prepared by The Brattle Group *et.al.*, June.

<sup>1</sup> Improved co-ordination between stakeholders is the first principle defined by OECD member countries in applying ICTs for the environment, see *OECD Council Recommendation on ICTs and the environment*, 2010, available at [www.oecd.org/sti/ict/green-ict](http://www.oecd.org/sti/ict/green-ict).

<sup>2</sup> For a discussion of smart water technologies see the OECD Technology Foresight Forum 2010 on “Smart ICTs and Green Growth”. In particular, webcasts and presentations by Richard Youngman, Cleantech Group, and Ian Oppermann, CSIRO Australia, [www.oecd.org/ict/TechnologyForesightForum](http://www.oecd.org/ict/TechnologyForesightForum).

<sup>3</sup> See for example an enquiry by the European Commission on competition in the European electricity sector, <http://ec.europa.eu/competition/sectors/energy/inquiry/index.html>, last accessed on 2 May 2011.

<sup>4</sup> Other studies highlighting the potential of ICT applications in the smart grid, although rarely covering direct and systemic environmental impacts include: Bio IS (2008), *Impacts of Information and Communication Technologies on Energy Efficiency*; The Climate Group/GeSI (2008), *SMART 2020*; EPRI (2008), *The Green Grid – Energy savings and Carbon emissions reductions enabled by a smart grid*.

<sup>5</sup> See Work Package 6, Deliverable D6-2, June 2010 at <http://seesgen-ict.rse-web.it>.

<sup>6</sup> See *Financial Times* (2010), “Gregor Czisch on the super-grid”, 13 July, <http://blogs.ft.com/energy-source/2010/07/13/gregor-czisch-on-the-super-grid>.

<sup>7</sup> EDF posted a press release on the website that contains suggestions on how residential customers could contribute to energy savings in the household. Parts of the release were picked up by national media as part of regular news coverage (see EDF, 2010).

<sup>8</sup> See for example a list of aggregators in the United Kingdom at: [www.nationalgrid.com/uk/Electricity/Balancing/demandside/aggregators/](http://www.nationalgrid.com/uk/Electricity/Balancing/demandside/aggregators/), last accessed 2 May 2011.

<sup>9</sup> See article by GE Digital Energy on “Distribution Substation Automation in Smart Grid”, no date, [www.gedigitalenergy.com/multilin/journals/issues/Winter09/9th-Distribution%20Substation%20Automation.pdf](http://www.gedigitalenergy.com/multilin/journals/issues/Winter09/9th-Distribution%20Substation%20Automation.pdf).

<sup>10</sup> These are specific electronic or ICT-based systems to monitor and control electricity grids. They have been in use for a long time and do not constitute novelties in the context of the smart grid.

<sup>11</sup> See for example *BusinessWeek* (2009), “How Italy beat the world to a smarter grid”, 16 November, [www.businessweek.com/globalbiz/content/nov2009/gb20091116\\_319929.htm](http://www.businessweek.com/globalbiz/content/nov2009/gb20091116_319929.htm).

<sup>12</sup> See, for example, Borenstein, S. (2006), “Customer Risk from Real-Time Retail Electricity Pricing: Bill Volatility and Hedgability”, NBER Working Paper No. 12524.

<sup>13</sup> See comments made by Bob Gilligan, VP Transmission & Distribution, GE Energy: EurActiv (2011), “Rising electricity bills: Will smart meters help consumers?”, 21 April, [www.euractiv.com/en/food/rising-electricity-bills-smart-meters-help-consumers-news-502921](http://www.euractiv.com/en/food/rising-electricity-bills-smart-meters-help-consumers-news-502921), last accessed on 2 May 2011.

<sup>14</sup> For details see SmartGridNews.com (2010), “Independent probe says heat (not smart meters) caused PG&E bills to soar”, 3 September; and California Public Utilities Commission (2010), “Independent PG&E Smart Meter Testing”, final report delivered in September.

15 France: *Que Choisir* (2010), “Remplacement des compteurs électriques. Passage en force du gouvernement”, 6 September; Germany: Forsa (2010).

16 In fact, the German study by Forsa confirms that consumers expect individual and societal benefits from smart meters. Provided with a list of nine potential advantages of smart metering, the following three were chosen most: 1. Reduction of environmental impacts, 2. Reduction of electricity costs, 3. Improved management and control of electricity use in the household.

17 A standard on “Requirements for Smart Meter Upgradeability” was published by the US Association of Electrical and Medical Imaging Equipment Manufacturers (NEMA), SG-AMI 1-2009.

18 See video presentation by Opower at the OECD Technology Foresight Forum 2010 on “Smart ICTs for Green Growth”, [www.oecd.org/ict/TechnologyForesightForum](http://www.oecd.org/ict/TechnologyForesightForum).

19 See case study of Cisco’s “Network Building Mediator” at [www.cisco.com/en/US/prod/collateral/ps6712/ps10447/ps10454/case\\_study\\_c36-543499.html](http://www.cisco.com/en/US/prod/collateral/ps6712/ps10447/ps10454/case_study_c36-543499.html), last accessed 2 May 2011.

20 See OECD workshop “Cloud computing for leaner and greener IT infrastructures in government (and businesses)” at the Internet Governance Forum (IGF) 2010, Lithuania. A workshop report is available at [www.oecd.org/InternetGovernance](http://www.oecd.org/InternetGovernance).

21 Initiatives such as Open Compute, GreenGrid, GreenTouch and others work on limiting the *relative* electricity and environmental footprints of large-scale computing, *e.g.* per task, per user, per storage unit. The focus here, however, is on the inevitable increases in *absolute* electricity use and the impacts of this trend.

22 See remarks on the importance of networked software systems for Better Place, a private start-up that aims to develop nationwide infrastructures for the charging and swapping of batteries: [www.betterplace.com/the-solution-ev-network-software](http://www.betterplace.com/the-solution-ev-network-software), last accessed 2 May 2011.

23 See ConEdison (2011), “My EV and my bill”, [www.coned.com/electricvehicles/my\\_ev\\_and\\_my\\_bill.asp](http://www.coned.com/electricvehicles/my_ev_and_my_bill.asp), last accessed 2 May 2011.

24 See PlaNYC (2010), “Exploring electric vehicle adoption in New York City”, January, [www.nyc.gov/html/om/pdf/2010/pr10\\_nyc\\_electric\\_vehicle\\_adoption\\_study.pdf](http://www.nyc.gov/html/om/pdf/2010/pr10_nyc_electric_vehicle_adoption_study.pdf).

25 See the research project “Drive-In” under the Carnegie Mellon-Portugal research programme, <http://drive-in.cmuportugal.org/>.

26 Estimates from Europe derive from a European Commission presentation “Background on energy in Europe”, prepared for the European Council, 4 February 2011; estimates for the United States come from EPRI (2011), “Estimating the costs and benefits of the smart grid”, March, EPRI, Palo Alto, CA.

27 See for example California Public Utilities Commission (2010), “Report to the Governor & the Legislature on Smart Grid Plans and Recommendations”, December.

28 See statement made by GE Energy, cited on [www.euractiv.com/en/food/rising-electricity-bills-smart-meters-help-consumers-news-502921](http://www.euractiv.com/en/food/rising-electricity-bills-smart-meters-help-consumers-news-502921), last accessed 2 May 2011.

29 OECD (forthcoming), “Machine-to-machine communications: connecting billions of devices”, OECD, Paris.

30 See Gartner reports at: [www.gartner.com/technology/research/it-ot-alignment](http://www.gartner.com/technology/research/it-ot-alignment), last accessed 2 May 2011.

31 See also OECD (2008), *OECD Recommendation of the Council on the Protection of Critical Information Infrastructures*, [C\(2008\)35](#).

32 See presentations and background documents at the OECD Conference “The Economics of Personal Data and Privacy: 30 Years after the OECD Privacy Guidelines”, 1 December 2010, [www.oecd.org/sti/privacyanniversary](http://www.oecd.org/sti/privacyanniversary).

33 This includes OECD (1980), *Recommendation of the Council concerning guidelines governing the protection of privacy and transborder flows of personal data* (“OECD Privacy Guidelines”) and the *OECD Ministerial declaration on the protection of privacy on global networks*, Ottawa 1998.

34 For a detailed analysis of the issues surrounding privacy and access to personal data, see the EU’s Article 29 Data Protection Working Party (2011), “Opinion 12/2011”, adopted 4 April, [http://ec.europa.eu/justice/policies/privacy/docs/wpdocs/2011/wp183\\_en.pdf](http://ec.europa.eu/justice/policies/privacy/docs/wpdocs/2011/wp183_en.pdf); and a thematic webpage on “The smart grid and privacy” by the Electronic Privacy Information Center (EPIC) <http://epic.org/privacy/smartgrid/smartgrid.html>. Moreover, *OECD Policy Guidance on RFID* provides some orientation for the consideration of privacy aspects in the area of smart metering and smart grid projects; available at [www.oecd.org/dataoecd/19/42/40892347.pdf](http://www.oecd.org/dataoecd/19/42/40892347.pdf).